

The logo for Vulcan, featuring the word "Vulcan" in a white, sans-serif font on a blue background with a green underline.

# The Electronic Anti-Scale System For Industrial Applications



No Salt  
No Chemicals  
No Maintenance

German Technology  
Absolutely Magnetism-Free





## Vulcan – the chemical-free solution

The Vulcan-Impulse-Technology treats the water with special electronic impulses that take away the adhesive power of the scale. Scale is simply washed away with the water as a fine powder.

Vulcan provides a salt-free and chemical-free solution for all types of scale-related problems in many industrial applications.



### Benefits of using Vulcan

- ▶ Maximized life of production equipment
- ▶ Lengthens maintenance intervals
- ▶ Increase in overall productivity
- ▶ More efficient use of energy consumption
- ▶ Reduction of chemical and salt costs
- ▶ An easier and less-frequent cleaning process
- ▶ No production loss during installation
- ▶ A fast pay-back of acquisition costs



Cooling tower

### Saving money with Vulcan

Cooling towers often suffer from scale buildup caused by the vaporization and cycling of water. Scale cannot evaporate, so when a new cycle of water is introduced, the scale builds up more and more. This type of hard compounded scale is expensive to remove so frequently. Vulcan reduces the amount of scale deposits and reduces the amount of required maintenance. It offers you a permanent solution without on-going costs, repairs or replacements.

## Installation example

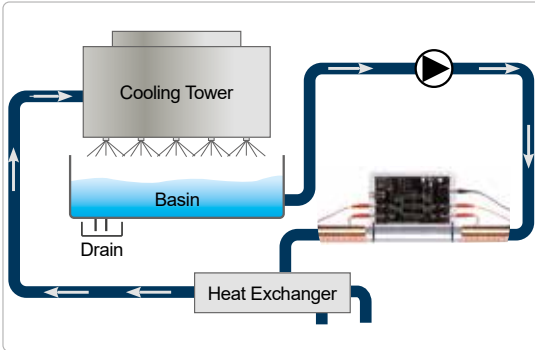

Open loop example

Vulcan should be installed just before the heat exchanger. Installation is simple and no pipe cutting is needed. Please ensure to regularly drain the circuit at the bottom of the basin or use a centrifugal filter to take away remaining solids from the cooling tower water.

## Application examples

- ▶ Cooling towers
- ▶ Heat exchangers
- ▶ Chillers & refrigeration systems
- ▶ Vacuum pumps and valves
- ▶ Grinders and mixers
- ▶ Condensers
- ▶ Industrial ovens and presses
- ▶ Food processing



Bottling plant



## Case study

"After installing the Vulcan unit, we were able to stop all chemical based cooling tower treatment. After approximately six months, almost no scale build up was observed.

Small amounts of scale that were found on the cooling tower are easily removed with the wipe of a finger. With these results, we can confirm the effectiveness of the Vulcan."



## Prevents Scale and Rust

- ✓ Reduction of existing scale in the piping system
- ✓ Installation without cutting the pipe
- ✓ From 1/2" up to 40" pipe diameter
- ✓ Works on all pipe materials – iron, copper, plastic, stainless steel, PVC, compound pipes, PE-X, etc.
- ✓ 100% maintenance-free
- ✓ Eco-friendly solution without salt or chemicals
- ✓ Prolongs life of machinery and equipment
- ✓ Important minerals remain in the water
- ✓ Long life – fully cast in acrylic
- ✓ 25 year international warranty

### Visible results of Vulcan water treatment



Piping system



Cooling tower grids

### Some clients

- ▶ Alcatel phones
- ▶ Haecker gelatine production
- ▶ Eberswalder sausage factory
- ▶ Beutelsbacher juice factory
- ▶ Freixenet sparkling wine
- ▶ Rhein chemistry
- ▶ Viessmann heating systems
- ▶ Daimler Chrysler

### Quality – Made in Germany

- ▶ Manufactured by Christiani Wassertechnik GmbH (CWT) in Germany
- ▶ Over 40 years of experience in physical water treatment
- ▶ Successful in more than 70 countries worldwide
- ▶ 25 years international warranty

