



SV DN 15÷25

PVC-U

Relief valve with inclined seat



SV DN 15÷25

The SV relief valve is used in the presence of batching pumps to prevent an undesired increase in pressure and maintain constant operating pressure.

RELIEF VALVE WITH INCLINED SEAT

- Whenever upstream pressure exceeds the level at which the spring is calibrated by the user, the valve will open under the pressure of the fluid, lowering pressure on the line and thereby protecting the components in the system. The valve automatically closes again when the operating pressure on the piston drops to the value to which the spring is calibrated.
- Metal parts isolated from fluid and from the environment
- Designed to permit easy installation and adjustment

Technical specifications	
Construction	Relief valve with inclined seat
Size range	DN 15 ÷ 25
Nominal pressure	16 bar
Temperature range	0 °C ÷ 60 °C
Adjustment range	0.3 - 4 bar
Coupling standards	Solvent welding: EN ISO 1452, EN ISO 15493, ISO 727, DIN 8062, DIN 8063 Thread: ISO 228-1, DIN 2999, ISO 7-1, BS 21, BS 10226
Reference standards	Construction criteria: EN ISO 1452, EN ISO 15493 Test methods and requirements: ISO 9393 Installation criteria: DVS 2204, DVS 2221, UNI 11242
Valve material	PVC-U
Seal material	EPDM, FKM
Control options	Manual control; automatic operation

TECHNICAL DATA

PRESSURE VARIATION ACCORDING TO TEMPERATURE

For water and non-hazardous fluids with regard to which the material is classified as CHEMICALLY RESISTANT. In other cases, a reduction of the nominal pressure PN is required (25 years with safety factor).



DIMENSIONS

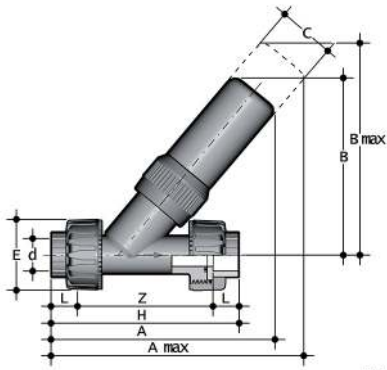

SVUIV

Relief valve with female union ends for solvent welding

d	DN	A	A max	B	B max	C	E	H	L	Z	g	EPDM Code	FKM Code
20	15	153	193	118	170	34	55	135	16	103	391	SVUIV020E	SVUIV020F
25	20	191	271	150	220	40	66	158	19	120	633	SVUIV025E	SVUIV025F
32	25	226	296	175	230	48	75	176	22	132	1106	SVUIV032E	SVUIV032F

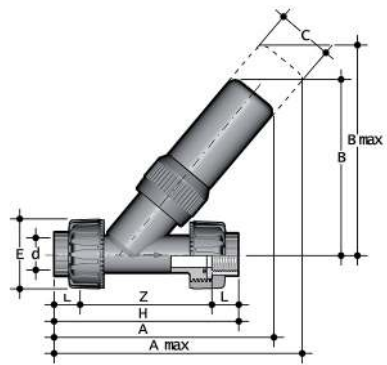

SVUFV

Relief valve with threaded BSP female union ends

R	DN	A	A max	B	B max	C	E	H	L	Z	g	EPDM Code	FKM Code
1/2"	15	153	193	118	170	34	55	135	15.0	112.0	391	SVUFV012E	SVUFV012F
3/4"	20	191	271	150	220	40	66	158	16.3	126.4	633	SVUFV034E	SVUFV034F
1"	25	226	296	175	230	48	75	176	19.1	144.8	1106	SVUFV100E	SVUFV100F

COMPONENTS

EXPLODED VIEW

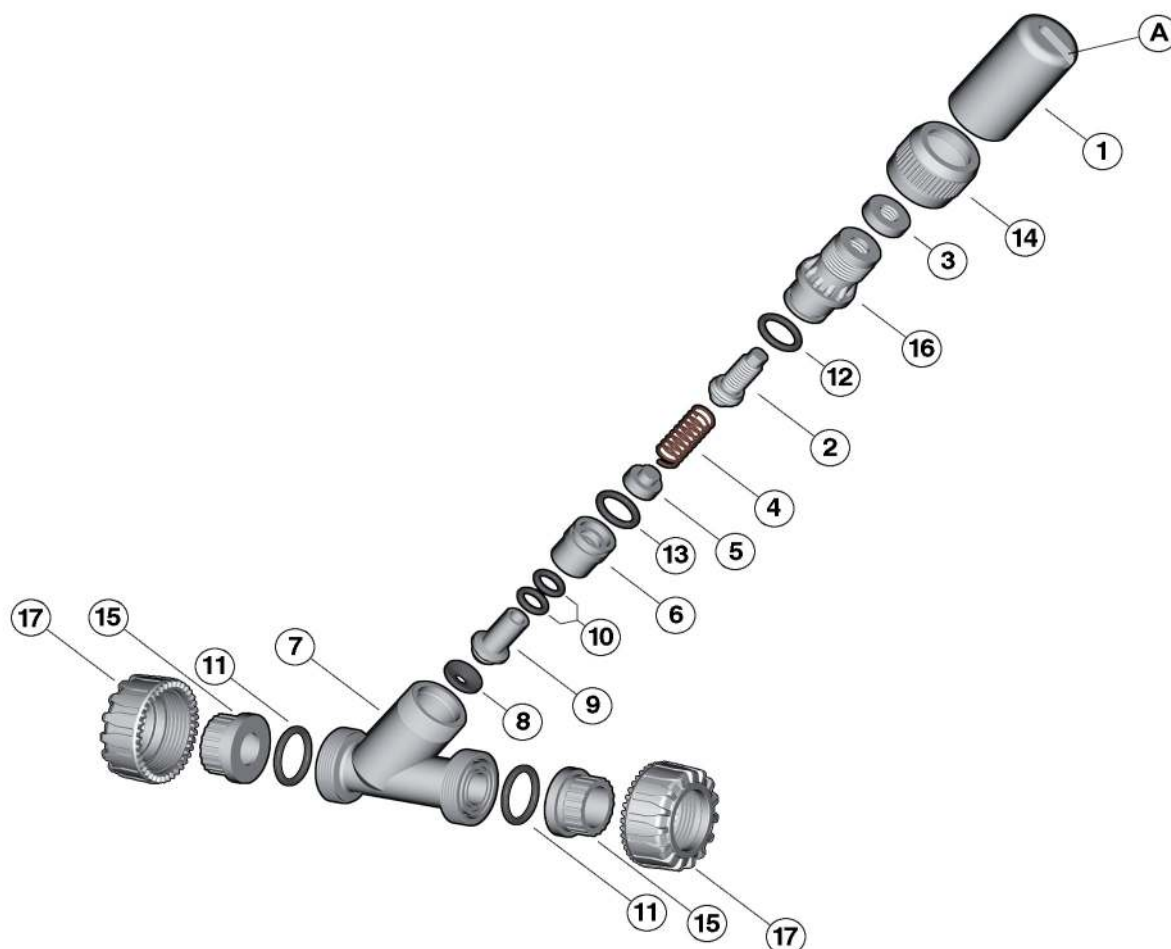

- | | | |
|---------------------------------------|---|--|
| 1 Protective cover (PVC-U - 1) | 7 Case (PVC-U - 1) | 13 Ext. support O-ring (EPDM-FKM - 1) |
| 2 Adjustment stem (PVC-U - 1) | 8 Flat seal (EPDM-FKM - 1) | 14 Union nut (PVC-U - 1) |
| 3 Locknut (PVC-U - 1) | 9 Piston (PVC-U - 1) | 15 End connector (PVC-U - 2) |
| 4 Spring (carbon steel - 1) | 10 Support O-Ring (EPDM-FKM - 2) | 16 Cover (PVC-U - 1) |
| 5 Guide (PVC-U - 1) | 11 Connector O-ring (EPDM-FKM - 2) | 17 Union nut (PVC-U - 2) |
| 6 Piston support (PVC-U - 1) | 12 Cover O-ring (EPDM - FKM - 1) | |

The material the component is made of and the quantity supplied are shown in brackets

DISASSEMBLY

- 1) Isolate the valve from the fluid flow.
- 2) Unscrew the protective cover (1), turning it anticlockwise.
- 3) Unscrew the union nut (14) anticlockwise and then remove the internal assembly (7), complete with all its components, from the case.
- 4) Remove the spring (4) and take off the guide (5).
- 5) Remove the piston support internal assembly (6) and the piston (9).
- 6) Remove the piston (9)
- 7) Unscrew the nut (3)
- 8) Turn the stem (2) clockwise to remove it completely from the cover (16).

ASSEMBLY

- 1) Insert the stem (2) into the cover (16) and screw it in, turning anticlockwise.
- 2) Screw in the nut (3)
- 3) Insert the piston (9) into the piston support (6)
- 4) Insert, in order: the piston internal assembly and support, the guide (5)
- 5) Insert the spring (4) into the cover (16)
- 6) Insert the cover (16) with the spring inside the body (7), fitting the pin into its guide
- 7) Insert the nut (14) on the stem and screw it on
- 8) Tighten the cover (1)



Note: during assembly operations, it is advisable to lubricate the rubber seals. Mineral oils are not recommended for this task as they react aggressively with EPDM rubber.

INSTALLATION

- 1) The valve may be installed in any position, complying with the direction of flow indicated by the arrow on the valve body.
During solvent welding, take the utmost care to ensure that the solvent cement does not penetrate the valve.

CALIBRATING THE TRIP THRESHOLD

- 1) Unscrew the protective cover (1), turning it anticlockwise.
- 2) Slacken the locknut (3)
- 3) Overturn the cover (1) and fit notch (A) over the stem square (2).
- 4) Turn the stem (2) clockwise to compress the spring (4), raising valve tripping pressure.
- 5) After completing the adjustment, tighten the locknut (3) and screw the cover (1) back onto the valve.

WARNINGS

All operations on equipment under pressure or containing compressed springs must be carried out under safe conditions for the operator.