



S1 - S2

PVC-U

TWO-WAY RADIAL DISMOUNTING SOLENOID VALVE



S1 – S2 DN 4÷15

The solenoid valve is the ideal solution for applications requiring many rapid actuation cycles and installations in confined spaces. Thanks to the absence of metal parts in contact with the fluid or the external environment, it can also be used in the presence of aggressive fluids. Ideal for use in fertigation benches.

TWO-WAY RADIAL DISMOUNTING SOLENOID VALVE

- 2-Way PVC-U body
- Installation flexibility and ease of maintenance: high-performance solenoid electric actuator designed to exceed 5 million maintenance-free operating cycles
- Adjustable circular section coil with IP65 protection class.
- Integrated override with the possibility of being installed in 3 different positions.
- Lever shutter in EPDM or FKM and lever in stainless steel.
- DIN 43650 electrical connector supplied as standard: includes LED indicator light and rectifier (in the case of an AC coil).

Technical specifications - S1-S3

Construction	2-way solenoid valve
Size range	S12: DN 4-6-8 S22: DN 8-10-15
Temperature range	0 °C ÷ 50 °C
Coupling standards	Solvent welding: EN ISO 1452, EN ISO 493, ISO 727, DIN 8063, ASTM D2467, BS 4346-1, ISO 727-2. Can be coupled to pipes according to ISO 161/1, DIN 8062, ASTM D1 1785/76, BS 3506, BS 3505 Thread: ISO 228-1, DIN 2999, ASTM D 2467 (NPT), BS 21, BS 10226, ISO 7-1
Valve material	PVC-U
Seal material	EPDM, FKM

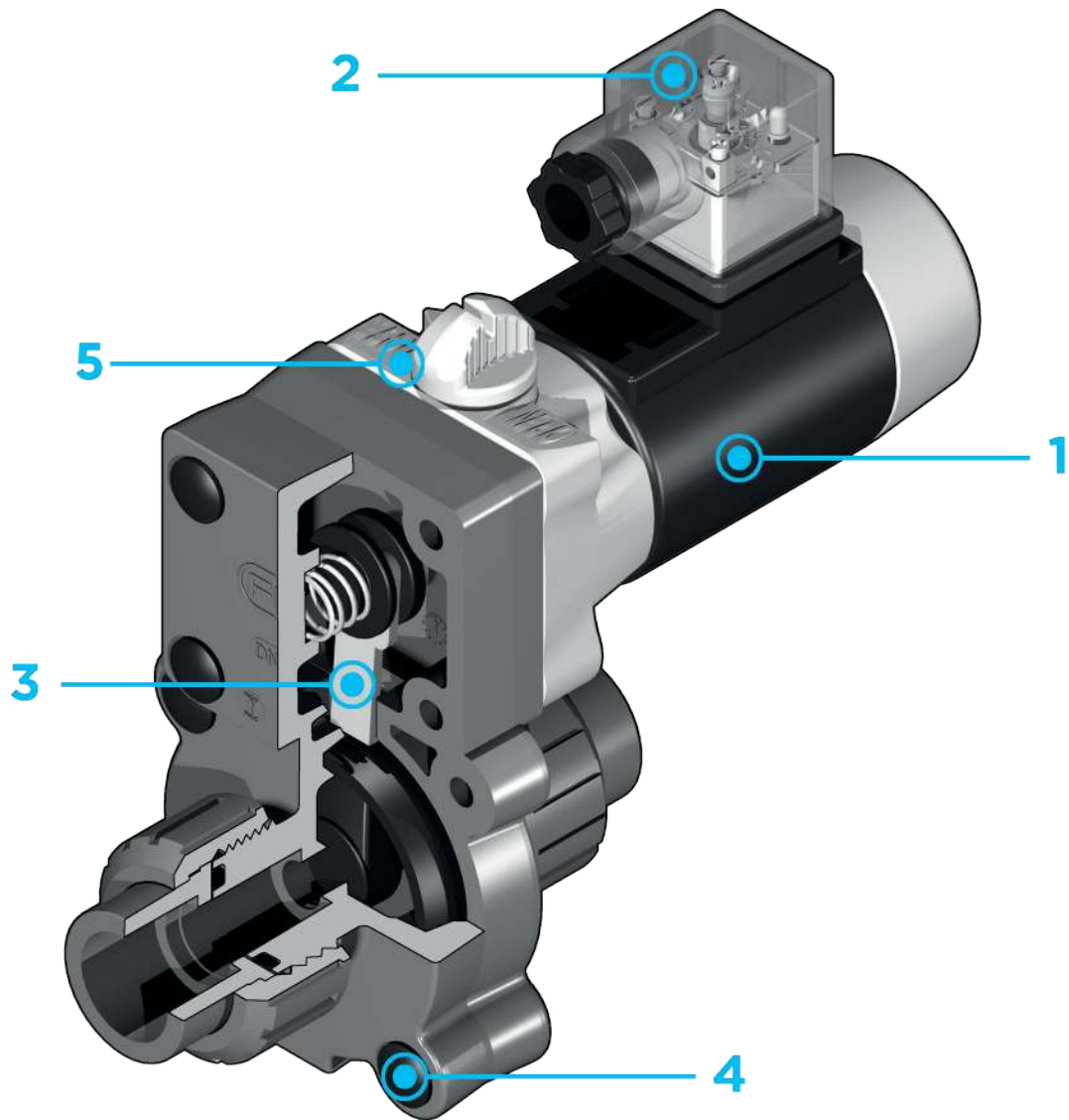

1 Installation flexibility and ease of maintenance: high-performance solenoid electric actuator with internal moving parts designed to exceed 5 million maintenance-free operating cycles Adjustable circular section coil with IP65 protection class.

2 DIN 43650 electrical connector supplied as standard: includes LED indicator light and rectifier (in the case of an AC coil).

3 Lever shutter in EPDM or FKM and lever in stainless steel.

4 Suitable for use with aggressive fluids: no metal component in contact with the fluid or the external environment; all the screws are covered by PE protection plugs.

5 Emergency override.

CONTROL OPTIONS

2/2 NORMALLY CLOSED

Off

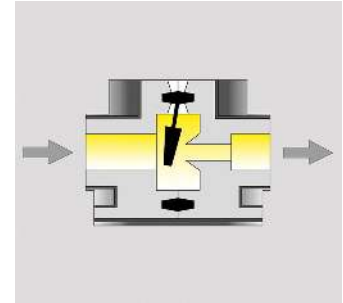
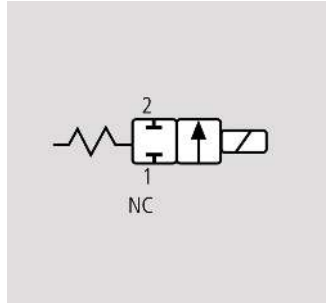
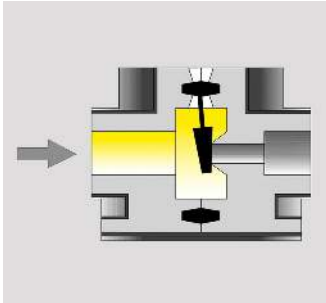

TECHNICAL DATA

TYPE S12 2-WAY VALVE PERFORMANCE

DN	4	6	8
PN	6	4	2
Kv(l/min)*	6.7	12.1	15.3

TYPE S22 2-WAY VALVE PERFORMANCE

DN	8	10	15
PN	6	4	2
Kv(l/min)*	27.5	34.2	58.3

* Q flow of litres per minute of water at a temperature of 20°C that will generate $\Delta p = 1$ bar pressure drop at a certain valve position.

The values shown in the table are calculated with the valve completely open.

GENERAL CHARACTERISTICS

Functional characteristics	lever shutter
S12 and S22 2-way valve control functions	NC
Body material	PVC-U
Seal material	EPDM or FKM.
Maximum environmental temperature	50° C
Maximum working fluid viscosity	38 cSt
Service	100% ED
Close time	~ 20 ms
Open time	~ 20 ms
Alternating current voltages	24V - 110V* - 230V
Frequency	50-60 Hz
Direct current voltages	24 V
Voltage tolerance	± 10%
S12 absorbed power	10 W
S22 absorbed power	20 W
Electrical protection	IP 65
Electrical connection	DIN 43650 connector with LED (1)
Coil thermal class	F (155°C)
Installation	In any position
Coil rotation	over 360°

*Voltage upon request

(1) Connector with internal electronic circuit specific to coil used

S1 – S2 PVC-U

TWO-WAY RADIAL DISMOUNTING SOLENOID VALVE

CODE

Character positions

	1	2	3	4	5	6	7	8	9	10	11	12	13	14
Valve type	de S													
	S1	1												
Series	S2	2												
Number of ways	Two-way		2											
	ISO female solvent welding (metric)			I										
	BSP female thread (inches)			F										
	ASTM female solvent welding (metric)			A										
	BS female solvent welding (metric)			L										
Joint type	NPT female solvent welding (metric)			N										
Material			PVC-U		V									
				DN 4		0	4							
				DN 6		0	6							
				DN 8		0	8							
Rated diameter				DN 10		1	0							
				DN 15		1	5							
						d10 metric		1	0					
						d12 metric		1	2					
						d16 metric		1	6					
						d20 metric		2	0					
				BSP - ASTM - BS - NPT - (inches) 1/4"				1	4					
				BSP - ASTM - BS - NPT - (inches) 3/8"				3	8					
Dimensions				BSP - ASTM - BS - NPT - (inches) 1/2"				1	2					
										EPDM				E
Seal material										FKM				F
										12V	0	1	2	
										24V	0	2	4	
										48V	0	4	8	
Coil voltage										110V	1	1	0	
										230V	2	3	0	
														Alternating
Current														Direct
														A
														C

E.g.: S12IV0616E024C 2-way solenoid valve, S1 series, DN6 d16, ISO unions, PVC-U solvent welding, EPDM seal, 24V DC

DIMENSIONS

S1 - S2 PVC-U

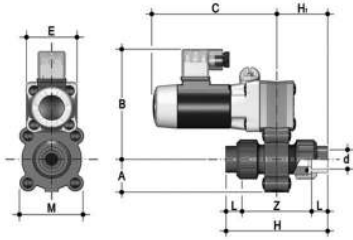

S12IV

2 way solenoid valve with female union ends for solvent welding Function: Normally closed

d	DN	A	B	C	H	H ₁	L	Z	E	M	g	EPDM Code	FKM Code
10	4-6-8	24	100	103	84	42	12	60	42	52	400	See code page	See code page
12	4-6-8	24	100	103	84	42	12	60	42	52	400	See code page	See code page
16	4-6-8	24	100	103	88	44	14	60	42	52	400	See code page	See code page

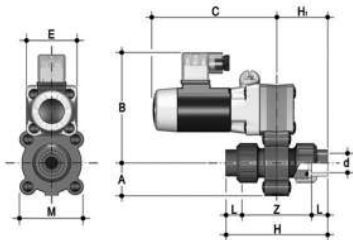

S22IV

2 way solenoid valve with female union ends for solvent welding Function: Normally closed

d	DN	A	B	C	H	H ₁	L	Z	E	M	g	EPDM Code	FKM Code
16	8-10-15	34	115	130	99	50	14	71	54	67	1000	See code page	See code page
20	8-10-15	34	115	130	103	52	16	71	54	67	1000	See code page	See code page

DIMENSIONS

S1 - S2 PVC-U

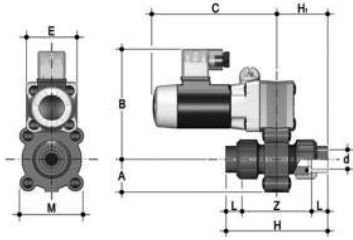

S12AV

2 way solenoid valve with BS female union ends for solvent welding.
Function: Normally closed

d	DN	A	B	C	H	H ₁	L	Z	E	M	g	EPDM Code	FKM Code
1/4"	4-6-8	24	100	103	92	46	16	60	42	52	400	See code page	See code page
3/8"	4-6-8	24	100	103	98	49	19	60	42	52	400	See code page	See code page

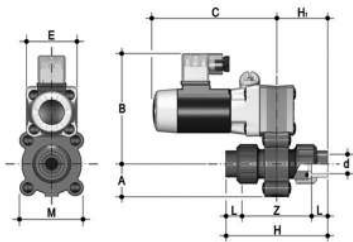

S22AV

2 way solenoid valve with ASTM female union ends for solvent welding.
Function: Normally closed

d	DN	A	B	C	H	H ₁	L	Z	E	M	g	EPDM Code	FKM Code
3/8"	8-10-15	34	115	130	109	55	19	71	54	67	1000	See code page	See code page
1/2"	8-10-15	34	115	130	116	58	22	72	54	67	1000	See code page	See code page

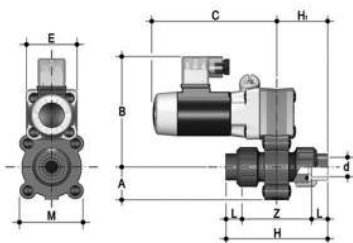

S12LV

2 way solenoid valve with BS female union ends for solvent welding.
Function: Normally closed

d	DN	A	B	C	H	H ₁	L	Z	E	M	g	EPDM Code	FKM Code
3/8"	4-6-8	24	100	103	88	44	14	60	42	52	400	See code page	See code page

DIMENSIONS

S1 - S2 PVC-U

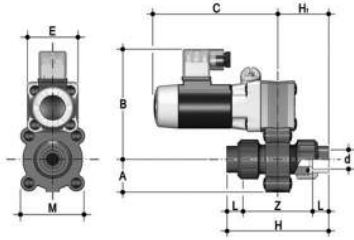

S22LV

2 way solenoid valve with BS female union ends for solvent welding.
Function: Normally closed

d	DN	A	B	C	H	H ₁	L	Z	E	M	g	EPDM Code	FKM Code
3/8"	8-10-15	34	115	130	99	50	14	71	54	67	1000	See code page	See code page
1/2"	8-10-15	34	115	130	104	52	16.5	71	54	67	1000	See code page	See code page

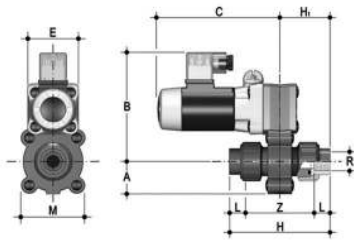

S12FV

2 way solenoid valve with gas cylinder thread female union ends. Function: Normally closed

R	DN	A	B	C	H	H ₁	L	Z	E	M	g	EPDM Code	FKM Code
1/4"	4-6-8	24	100	103	85	42	11	63	42	52	400	See code page	See code page
3/8"	4-6-8	24	100	103	86	43	11.5	63	42	52	400	See code page	See code page

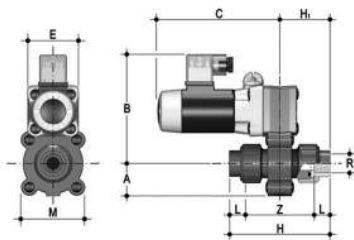

S22FV

2 way solenoid valve with gas cylinder thread female union ends. Function: Normally closed

R	DN	A	B	C	H	H ₁	L	Z	E	M	g	EPDM Code	FKM Code
3/8"	8-10-15	34	115	130	97	48.5	11.5	74	54	67	1000	See code page	See code page
1/2"	8-10-15	34	115	130	105	52.5	15	75	54	67	1000	See code page	See code page

DIMENSIONS

S1 - S2 PVC-U

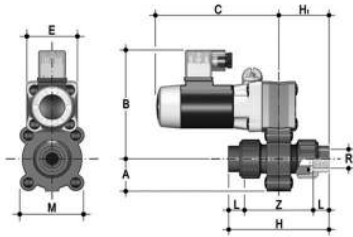

S12NV

2 way solenoid valve with NPT thread female union ends.
Function: Normally closed

R	DN	A	B	C	H	H ₁	L	Z	E	M	g	EPDM Code	FKM Code
1/4"	4-6-8	24	100	103	91	45	15	61	42	52	400	See code page	See code page
3/8"	4-6-8	24	100	103	92	46	16	60	42	52	400	See code page	See code page

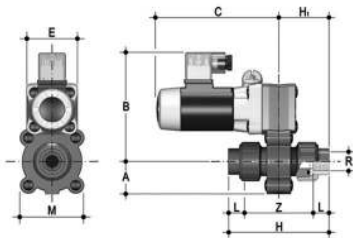

S22NV

2 way solenoid valve with NPT thread female union ends.
Function: Normally closed

R	DN	A	B	C	H	H ₁	L	Z	E	M	g	EPDM Code	FKM Code
3/8"	8-10-15	34	115	130	103	51.5	16	71	54	67	1000	See code page	See code page
1/2"	8-10-15	34	115	130	112	56	20.5	71	54	67	1000	See code page	See code page

COMPONENTS

EXPLODED VIEW

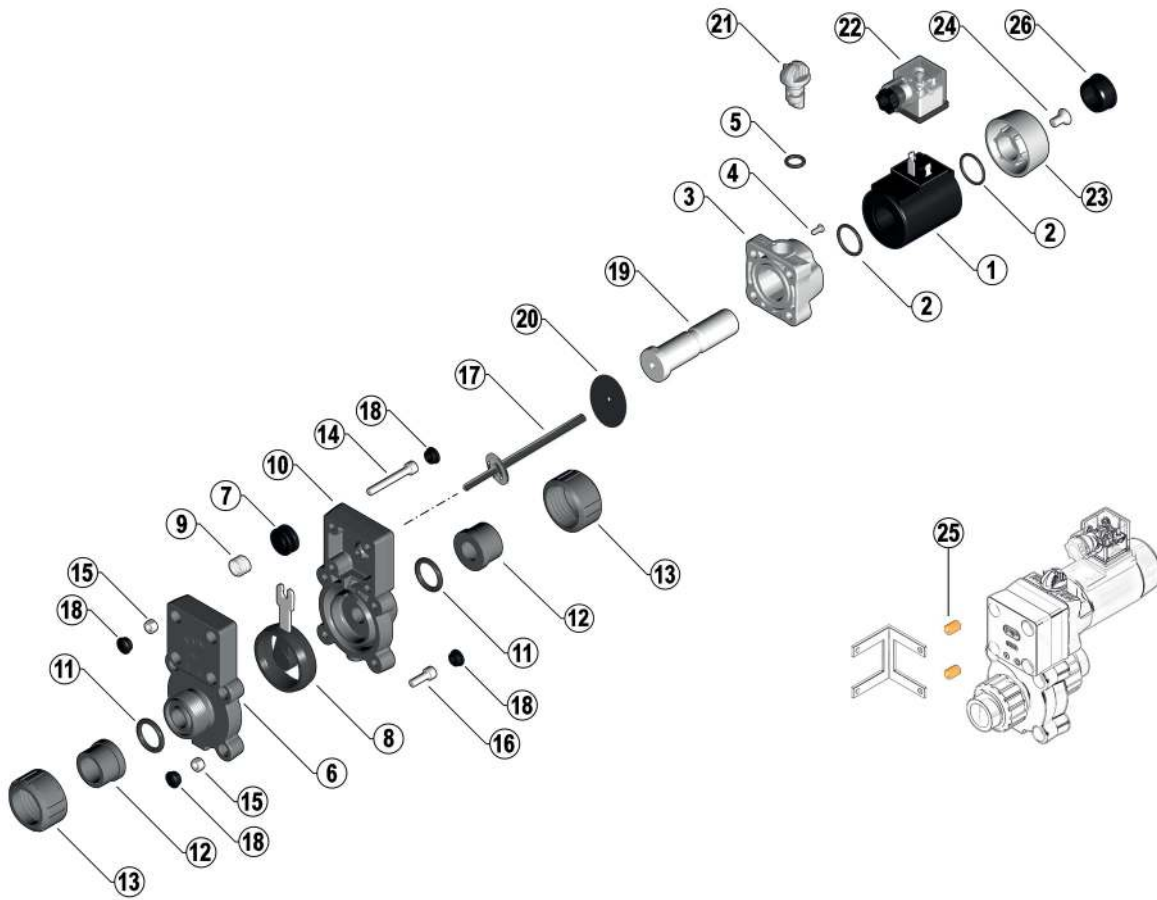

- | | | |
|--|---|--|
| 1 Coil (PA-GR - 1)* | 10 Lower semi-body (PVC-U - 1) | 19 Actuator (STAINLESS steel - 1) |
| 2 O-Ring (EPDM - 2)* | 11 O-Ring (EPDM - FKM - 2)* | 20 Diaphragm seal (VMQ-1) |
| 3 Override housing (PP-GR - 1) | 12 End connector (PVC-U - 2) | 21 Override (PP-GR - 1) |
| 4 Screw (STAINLESS steel - 1) | 13 Union nut (PVC-U - 2)* | 22 Connector (1)* |
| 5 O-Ring (EPDM - 1)* | 14 Fixing screws (stainless steel - 4) | 23 Bonnet Coil (PP-GR - 1) |
| 6 Upper semi-body (PVC-U - 1) | 15 Fixing nuts (stainless steel - 8) | 24 Bonnet fixing screws (stainless steel - 1) |
| 7 Spring return end (PP-GR - 1) | 16 Fixing screws (stainless steel - 4) | 25 Fixing nuts (Brass - 2) |
| 8 Shutter (EPDM-FKM - 1)* | 17 Stem (STAINLESS steel - 1) | 26 Protection plug (PE - 1) |
| 9 Spring return (stainless steel - 1) | 18 Protection plug (PE - 8) | |

* Spare parts

The material the component is made of and the quantity supplied are shown in brackets

DISASSEMBLY

- 1) Unscrew the union nuts (13) and extract the valve from the system and remove the O-rings (11).
- 2) Remove the protection plug (26), unscrew the coil fixing screw (24) and remove the coil bonnet (23).
- 3) Remove the coil (1) and O-rings (2).
- 4) Remove the protection plugs (18) and screws (14).
- 5) Separate the actuator unit from the valve and remove the stem (17) and diaphragm seal (20).
- 6) Unscrew the stop screw (4) and remove the override (21) and O-ring (5). Remove the actuator (19) from the override housing (3).
- 7) Unscrew the screws (16) and separate the two semi-bodies (6 - 10) extracting the shutter (8).
- 8) Remove the spring return (9) from the spring return end (7) and the latter from the shutter (8).

ASSEMBLY

- 1) Insert the spring return end (7) on the shutter rod (8) and spring (9) on the spring return end (7).
- 2) Place the shutter (8) on the upper semi-body (6) being careful that the spring (9) is correctly positioned in its seat.
- 3) Couple the two semi-bodies (6-10) cross tightening the screws (16) according to the recommended torque in the instruction sheet.
- 4) Fully insert the actuator (19) in the override housing (3).
- 5) Place the O-ring (5) on the override (21) and tighten the stop screw (4). Make sure the override freely rotates and move it to the "close" position.
- 6) Insert the stem (17) inside the actuator hole (19), place the seal (20) in the override housing seat.
- 7) Reassemble the actuator on the valve body cross tightening the screws (14) according to the recommended torque in the instruction sheet.
- 8) Reassemble the protection plugs (18), position the coil (1), the coil bonnet (23) and tighten the screw (24) according to the maximum recommended torque in the instruction sheet. Replace the protection plug (26).



Note: during mounting operations, it is advisable to lubricate the rubber seals. Mineral oils are not recommended for this task as they react aggressively with EPDM rubber.

INSTALLATION

- 1) Fluid must be clean without suspended substances. For this reason, we recommend installing an impurity filter upstream from the valve.
- 2) Two or more long bracketing nuts (25) can be used to anchor to the system.
- 3) When electrically connecting the electromagnet, remember that solenoids are powered in direct current (DC) or rectified (for alternating current AC versions). A rectifier that is supplied with the connector must be used for alternating current.