

 *Aliaxis*



ISO-BSP FITTINGS

PVC-C

TemperFIP100® adaptor fittings

ISO-BSP FITTINGS

Series of fittings designed for conveying fluids under pressure with threaded and cold chemical solvent weld jointing systems (solvent welding) using suitable solvent cement (TemperGLUE WELD-ON) and cleaner-primer.

TEMPERFIP100® ADAPTOR FITTINGS

| Technical specifications | |
|----------------------------|---|
| Size range | d 16 ÷ 63 (mm); R 3/8" ÷ 2" |
| Nominal pressure | PN 16 with water at 20° C |
| Temperature range | 0 °C ÷ 100 °C |
| Coupling standards | Solvent welding: EN ISO 15493 Can be coupled to pipes according to EN ISO 15493 Thread: ISO 228-1, DIN 2999 |
| Reference standards | Construction criteria: EN ISO 15493 Test methods and requirements: EN ISO 15493 Installation criteria: DVS 2204, DVS 2221, UNI 11242 |
| Fitting material | PVC-C |
| Seal material | EPDM, FKM |

TECHNICAL DATA

REGRESSION CURVE FOR PVC-C FITTINGS

Regression coefficients in accordance with standard EN ISO 15493 for minimum MRS = 20 N/mm² (MPa).

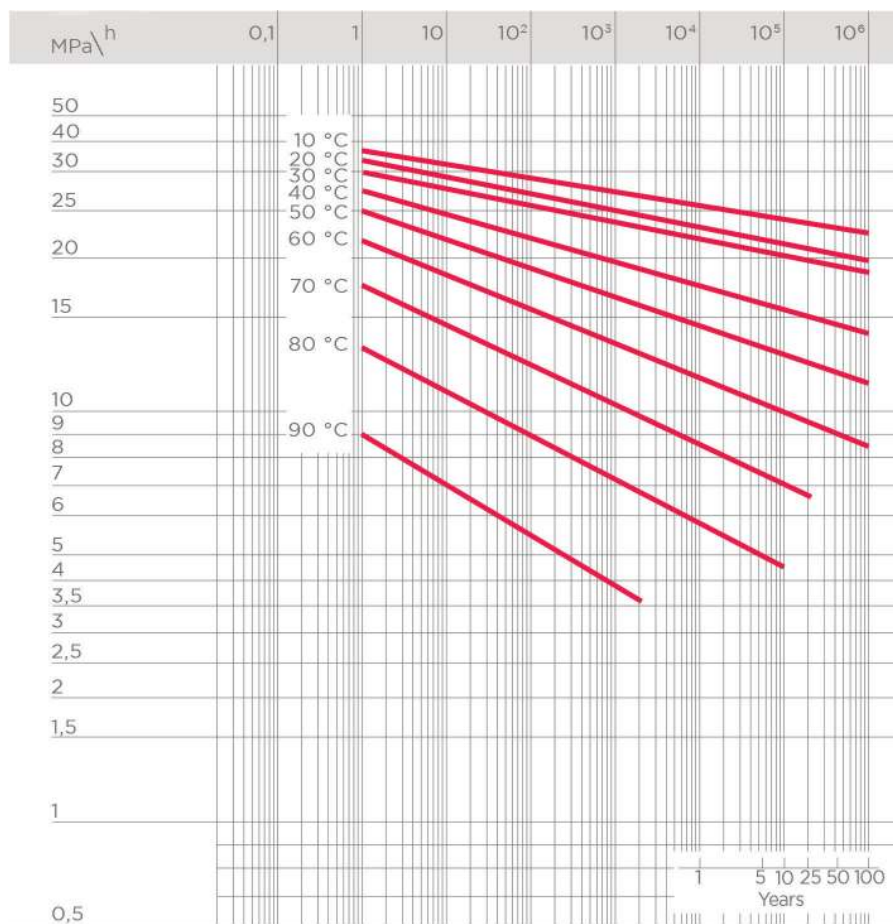

PRESSURE VARIATION ACCORDING TO TEMPERATURE

For water and non-hazardous fluids for which the material is classified as CHEMICALLY RESISTANT (life expectancy 25 years). In other cases, a reduction of the nominal pressure PN is required.

Note

When using PVC-C at working temperatures higher than 90°, it is advisable to first contact the service centre.



DIMENSIONS

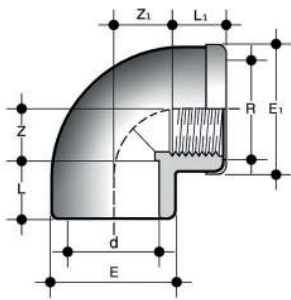

GIMC

90° elbow with reinforced solvent weld socket d and BSP threaded female end R with STAINLESS steel reinforcing ring

| d x R | PN | E | E ₁ | L | L ₁ | Z | Z ₁ | g | Code |
|-------------|----|------|----------------|----|----------------|----|----------------|-----|------------|
| 16 x 3/8" | 16 | 23,5 | 24,5 | 14 | 11,4 | 10 | 13 | 22 | GIMC016038 |
| 20 x 1/2" | 16 | 28,5 | 29,5 | 16 | 15 | 12 | 13 | 33 | GIMC020012 |
| 25 x 3/4" | 16 | 35 | 36 | 19 | 16,3 | 14 | 17 | 53 | GIMC025034 |
| 32 x 1" | 16 | 43 | 44 | 22 | 19,1 | 18 | 20,5 | 94 | GIMC032100 |
| 40 x 1 1/4" | 16 | 50 | 51 | 26 | 21,4 | 22 | 27 | 104 | GIMC040114 |
| 50 x 1 1/2" | 16 | 61 | 62 | 31 | 21,4 | 27 | 37 | 203 | GIMC050112 |
| 63 x 2" | 16 | 76 | 77 | 38 | 25,7 | 33 | 46 | 380 | GIMC063200 |

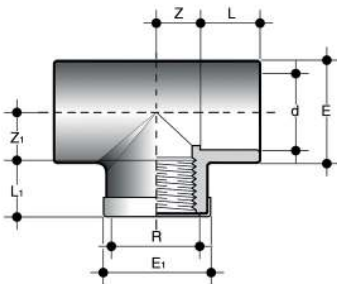

TIMC

90° Tee with reinforced solvent weld socket d and BSP threaded female end R with STAINLESS steel reinforcing ring

| d x R | PN | E | E ₁ | L | L ₁ | Z | Z ₁ | g | Code |
|-------------|----|------|----------------|----|----------------|------|----------------|-----|------------|
| 16 x 3/8" | 16 | 23,5 | 24,5 | 14 | 11,4 | 9 | 11 | 25 | TIMC016038 |
| 20 x 1/2" | 16 | 28,5 | 29,5 | 16 | 15 | 12 | 13 | 40 | TIMC020012 |
| 25 x 3/4" | 16 | 35 | 36 | 19 | 16,3 | 15 | 17 | 63 | TIMC025034 |
| 32 x 1" | 16 | 43 | 44 | 22 | 19,1 | 18 | 21 | 118 | TIMC032100 |
| 40 x 1 1/4" | 16 | 50 | 51 | 26 | 21,4 | 21,5 | 27 | 137 | TIMC040114 |
| 50 x 1 1/2" | 16 | 61 | 62 | 31 | 21,4 | 27 | 37 | 231 | TIMC050112 |
| 63 x 2" | 16 | 76 | 77 | 38 | 25,7 | 33,5 | 46 | 457 | TIMC063200 |

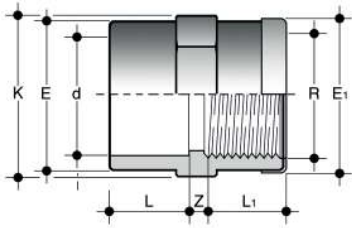

MIMC

Double socket with solvent weld socket d and BSP threaded female end r with STAINLESS steel reinforcing ring

| d x R | PN | E | E ₁ | K | L | L ₁ | Z | g | Code |
|-------------|----|------|----------------|----|----|----------------|-----|-----|------------|
| 16 x 3/8" | 16 | 23,5 | 24,5 | 24 | 14 | 11,4 | 5,6 | 15 | MIMC016038 |
| 20 x 1/2" | 16 | 28,5 | 29,5 | 29 | 16 | 15 | 4 | 25 | MIMC020012 |
| 25 x 3/4" | 16 | 35 | 36 | 35 | 19 | 16,3 | 5 | 38 | MIMC025034 |
| 32 x 1" | 16 | 43 | 44 | 43 | 22 | 19,1 | 6 | 58 | MIMC032100 |
| 40 x 1 1/4" | 16 | 50 | 51 | 50 | 26 | 21,4 | 5 | 66 | MIMC040114 |
| 50 x 1 1/2" | 16 | 61 | 62 | 61 | 31 | 21,4 | 8 | 109 | MIMC050112 |
| 63 x 2" | 16 | 76 | 77 | 76 | 38 | 25,7 | 7,5 | 196 | MIMC063200 |

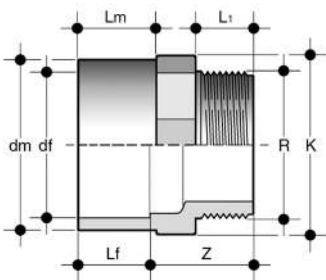

KIFC

Double adaptor with solvent weld socket df, solvent weld spigot dm and BSP threaded male end R

| dm x df x R | PN | K | L ₁ | Lf | Lm | Z | g | Code |
|------------------|----|----|----------------|----|----|------|-----|---------------|
| 20 x 16 x 3/8" | 16 | 24 | 11,4 | 14 | 16 | 25,5 | 7 | KIFC020016038 |
| 25 x 20 x 1/2" | 16 | 30 | 15 | 16 | 19 | 30 | 16 | KIFC025020012 |
| 32 x 25 x 3/4" | 16 | 34 | 16,3 | 19 | 22 | 27,5 | 23 | KIFC032025034 |
| 40 x 32 x 1" | 16 | 42 | 19,1 | 22 | 26 | 32 | 38 | KIFC040032100 |
| 50 x 40 x 1 1/4" | 16 | 52 | 21,4 | 26 | 31 | 35,5 | 65 | KIFC050040114 |
| 63 x 50 x 1 1/2" | 16 | 65 | 21,4 | 31 | 38 | 39,5 | 113 | KIFC063050112 |
| 75 x 63 x 2" | 16 | 75 | 25,7 | 38 | 44 | 41 | 158 | KIFC075063200 |

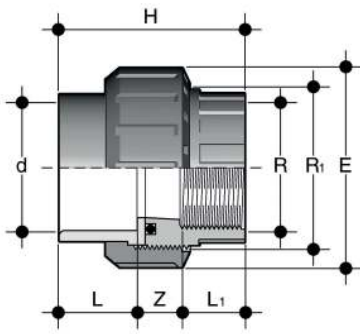

BIFC

Union with solvent weld socket d and BSP threaded female end R with O-ring in EPDM

| d x R | R ₁ | PN | E | H | L | L ₁ | Z | g | Code |
|-------------|----------------|----|----|----|----|----------------|------|-----|-------------|
| 16 x 3/8" | 3/4" | 16 | 33 | 41 | 14 | 11,4 | 15,6 | 25 | BIFC016038E |
| 20 x 1/2" | 1" | 16 | 41 | 45 | 16 | 15 | 14 | 40 | BIFC020012E |
| 25 x 3/4" | 1 1/4" | 16 | 51 | 51 | 19 | 16,3 | 15,7 | 68 | BIFC025034E |
| 32 x 1" | 1 1/2" | 16 | 58 | 57 | 22 | 19,1 | 15,9 | 93 | BIFC032100E |
| 40 x 1 1/4" | 2" | 16 | 72 | 67 | 26 | 21,4 | 19,6 | 158 | BIFC040114E |
| 50 x 1 1/2" | 2 1/4" | 16 | 79 | 72 | 31 | 21,4 | 19,6 | 193 | BIFC050112E |
| 63 x 2" | 2 3/4" | 16 | 98 | 88 | 38 | 25,7 | 24 | 345 | BIFC063200E |

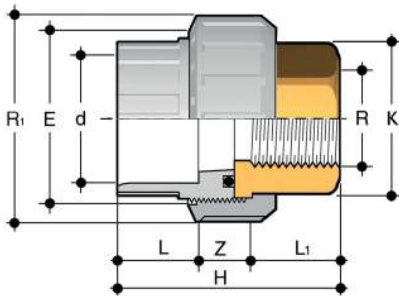

BIFOC

Adaptor union in PVC-C/brass with solvent weld socket d and BSP threaded brass female end R with O-Ring in EPDM

| d x R | R ₁ | PN | E | H | K | L | L ₁ | Z | g | Code |
|-------------|----------------|----|----|------|----|----|----------------|------|------|--------------|
| 16 x 3/8" | 3/4" | 16 | 33 | 45,5 | 20 | 14 | 13,5 | 18 | 55 | BIFOC016038E |
| 20 x 1/2" | 1" | 16 | 41 | 48,5 | 25 | 16 | 16,5 | 16 | 88,5 | BIFOC020012E |
| 25 x 3/4" | 1 1/4" | 16 | 50 | 54,5 | 32 | 19 | 18,5 | 17 | 165 | BIFOC025034E |
| 32 x 1" | 1 1/2" | 16 | 58 | 59,5 | 38 | 22 | 19,5 | 18 | 187 | BIFOC032100E |
| 40 x 1 1/4" | 2" | 16 | 72 | 68,5 | 48 | 26 | 21,5 | 21 | 379 | BIFOC040114E |
| 50 x 1 1/2" | 2 1/4" | 16 | 79 | 84,5 | 55 | 31 | 23 | 30,5 | 475 | BIFOC050112E |
| 63 x 2" | 2 3/4" | 16 | 98 | 94,5 | 69 | 38 | 27 | 29,5 | 837 | BIFOC063200E |

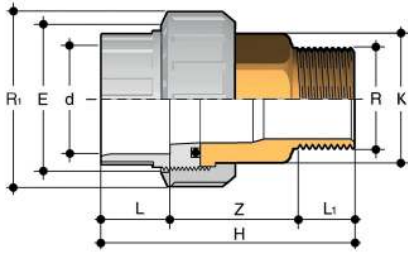

BIROC

Adaptor union in PVC-C/brass with solvent weld socket d and BSP threaded brass male end R with O-Ring in EPDM

| d x R | R ₁ | PN | E | H | K | L | L ₁ | Z | g | Code |
|-------------|----------------|----|----|-------|----|----|----------------|------|-------|--------------|
| 16 x 3/8" | 3/4" | 16 | 33 | 58,5 | 20 | 14 | 10,5 | 34 | 81 | BIROC016038E |
| 20 x 1/2" | 1" | 16 | 41 | 65 | 25 | 16 | 13,5 | 35,5 | 133,5 | BIROC020012E |
| 25 x 3/4" | 1 1/4" | 16 | 50 | 72,5 | 32 | 19 | 15 | 38,5 | 223 | BIROC025034E |
| 32 x 1" | 1 1/2" | 16 | 58 | 80 | 38 | 22 | 17,5 | 40,5 | 294 | BIROC032100E |
| 40 x 1 1/4" | 2" | 16 | 72 | 91 | 48 | 26 | 19,5 | 45,5 | 558 | BIROC040114E |
| 50 x 1 1/2" | 2 1/4" | 16 | 79 | 101 | 55 | 31 | 19,5 | 50,5 | 696 | BIROC050112E |
| 63 x 2" | 2 3/4" | 16 | 98 | 122,5 | 69 | 38 | 24 | 60,5 | 1196 | BIROC063200E |

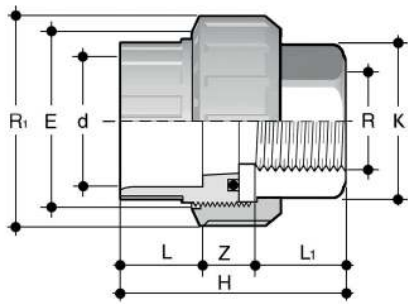

BIFXC

Adaptor union in PVC-C/STAINLESS steel with solvent weld socket d and BSP threaded STAINLESS steel female end R with O-Ring in EPDM or FKM

| d x R | R ₁ | PN | E | H | K | L | L ₁ | Z | g | EPDM code | FKM code |
|-------------|----------------|----|----|------|----|----|----------------|------|------|--------------|--------------|
| 16 x 3/8" | 3/4" | 16 | 33 | 45,5 | 20 | 14 | 13,5 | 18 | 52 | BIFXC016038E | BIFXC016038F |
| 20 x 1/2" | 1" | 16 | 41 | 48,5 | 25 | 16 | 16,5 | 16 | 83,5 | BIFXC020012E | BIFXC020012F |
| 25 x 3/4" | 1 1/4" | 16 | 50 | 54,5 | 32 | 19 | 18,5 | 17 | 156 | BIFXC025034E | BIFXC025034F |
| 32 x 1" | 1 1/2" | 16 | 58 | 59,5 | 38 | 22 | 19,5 | 18 | 176 | BIFXC032100E | BIFXC032100F |
| 40 x 1 1/4" | 2" | 16 | 72 | 68,5 | 48 | 26 | 21,5 | 21 | 361 | BIFXC040114E | BIFXC040114F |
| 50 x 1 1/2" | 2 1/4" | 16 | 79 | 84,5 | 55 | 31 | 23 | 30,5 | 450 | BIFXC050112E | BIFXC050112F |
| 63 x 2" | 2 3/4" | 16 | 98 | 94,5 | 69 | 38 | 27 | 29,5 | 792 | BIFXC063200E | BIFXC063200F |

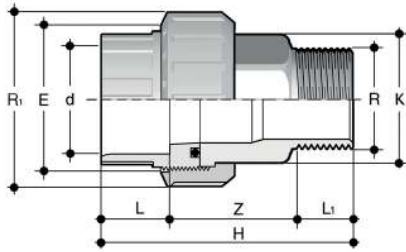

BIRXC

Adaptor union in PVC-C/STAINLESS steel with solvent weld socket d and BSP threaded STAINLESS steel male end R with O-Ring in EPDM or FKM

| d x R | R _i | PN | E | H | K | L | L _i | Z | g | EPDM code | FKM code |
|------------|----------------|----|----|-------|----|----|----------------|------|-------|--------------|--------------|
| 16 x 3/8" | 3/4" | 16 | 33 | 58,5 | 20 | 14 | 10,5 | 34 | 76 | BIRXC016038E | BIRXC016038F |
| 20 x 1/2" | 1" | 16 | 41 | 65 | 25 | 16 | 13,5 | 35,5 | 125,5 | BIRXC020012E | BIRXC020012F |
| 25 x 3/4" | 1"1/4 | 16 | 50 | 72,5 | 32 | 19 | 15 | 38,5 | 219 | BIRXC025034E | BIRXC025034F |
| 32 x 1" | 1"1/2 | 16 | 58 | 80 | 38 | 22 | 17,5 | 40,5 | 275 | BIRXC032100E | BIRXC032100F |
| 40 x 1"1/4 | 2" | 16 | 72 | 91 | 48 | 26 | 19,5 | 45,5 | 524 | BIRXC040114E | BIRXC040114F |
| 50 x 1"1/2 | 2"1/4 | 16 | 79 | 101 | 55 | 31 | 19,5 | 50,5 | 654 | BIRXC050112E | BIRXC050112F |
| 63 x 2" | 2"3/4 | 16 | 98 | 122,5 | 69 | 38 | 24 | 60,5 | 1124 | BIRXC063200E | BIRXC063200F |

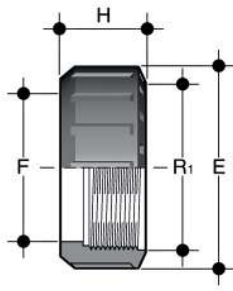

EFC

Union nut with BSP thread for union types BIC, BIFC, BFC, BLC, BIRC, BIFOC, BIROC, BIFXC, BIRXC.

| R ₁ | d BIV | PN | E | F | H | g | Code |
|----------------|-------|----|----|----|----|-----|--------|
| 3/4" | 16 | 16 | 33 | 22 | 21 | 9 | EFC034 |
| 1" | 20 | 16 | 41 | 28 | 22 | 13 | EFC100 |
| 1"1/4 | 25 | 16 | 50 | 36 | 25 | 22 | EFC114 |
| 1"1/2 | 32 | 16 | 58 | 42 | 27 | 30 | EFC112 |
| 2" | 40 | 16 | 72 | 53 | 30 | 50 | EFC200 |
| 2"1/4 | 50 | 16 | 79 | 59 | 34 | 68 | EFC214 |
| 2"3/4 | 63 | 16 | 98 | 74 | 38 | 120 | EFC234 |

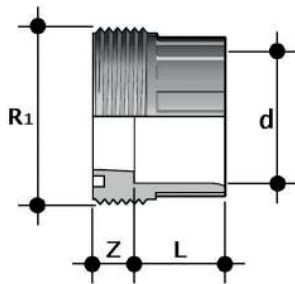

F/BIC

Union bush for solvent welding, metric series

| d | R ₁ | PN | L | Z | g | Code |
|----|----------------|----|----|----|-----|---------|
| 16 | 3/4" | 16 | 14 | 10 | 9 | FBIC016 |
| 20 | 1" | 16 | 16 | 10 | 13 | FBIC020 |
| 25 | 1"1/4 | 16 | 19 | 10 | 25 | FBIC025 |
| 32 | 1"1/2 | 16 | 22 | 10 | 31 | FBIC032 |
| 40 | 2" | 16 | 26 | 12 | 58 | FBIC040 |
| 50 | 2"1/4 | 16 | 31 | 14 | 63 | FBIC050 |
| 63 | 2"3/4 | 16 | 38 | 19 | 119 | FBIC063 |

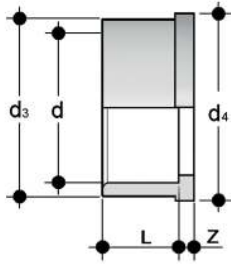

Q/BIC

Union end for solvent welding, metric series

| d | PN | d ₃ | d ₄ | L | Z | g | Code |
|----|----|----------------|----------------|----|---|----|---------|
| 16 | 16 | 22 | 24 | 14 | 3 | 5 | QBIC016 |
| 20 | 16 | 27,5 | 30,1 | 16 | 3 | 10 | QBIC020 |
| 25 | 16 | 36 | 38,8 | 19 | 3 | 16 | QBIC025 |
| 32 | 16 | 41,5 | 44,7 | 22 | 3 | 23 | QBIC032 |
| 40 | 16 | 53 | 56,5 | 26 | 3 | 40 | QBIC040 |
| 50 | 16 | 59 | 62,6 | 31 | 3 | 44 | QBIC050 |
| 63 | 16 | 74 | 78,4 | 38 | 3 | 82 | QBIC063 |

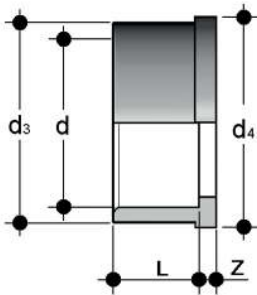

Q/BAC

Union end for solvent welding, ASTM series

| d | PN | d ₃ | d ₄ | L | Z | g | Code |
|-------|----|----------------|----------------|------|-----|-----|---------|
| 1/2" | 16 | 27,5 | 30,1 | 22,7 | 3,5 | 17 | QBAC012 |
| 3/4" | 16 | 36 | 38,8 | 25,9 | 3,7 | 25 | QBAC034 |
| 1" | 16 | 41,5 | 44,7 | 29,2 | 3 | 36 | QBAC100 |
| 1"1/4 | 16 | 53 | 56,5 | 32 | 5 | 63 | QBAC114 |
| 1"1/2 | 16 | 59 | 62,6 | 35 | 5 | 86 | QBAC112 |
| 2" | 16 | 74 | 78,4 | 38,5 | 5,5 | 143 | QBAC200 |

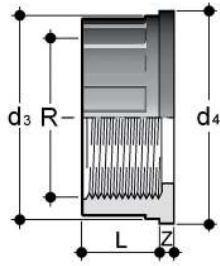

Q/BFC

Union end with BSP female thread

| R | PN | d ₃ | d ₄ | L | Z | g | Code |
|-------|----|----------------|----------------|------|-----|----|---------|
| 3/8" | 16 | 22 | 24 | 11,4 | 4,5 | 5 | QBFC038 |
| 1/2" | 16 | 27,5 | 30,1 | 15 | 5 | 9 | QBFC012 |
| 3/4" | 16 | 36 | 38,8 | 16,3 | 5 | 17 | QBFC034 |
| 1" | 16 | 41,5 | 44,7 | 19,1 | 5,5 | 23 | QBFC100 |
| 1"1/4 | 16 | 53 | 56,5 | 21,4 | 5,5 | 37 | QBFC114 |
| 1"1/2 | 16 | 59 | 62,6 | 21,4 | 5,5 | 44 | QBFC112 |
| 2" | 16 | 74 | 78,4 | 25,7 | 5,5 | 79 | QBFC200 |

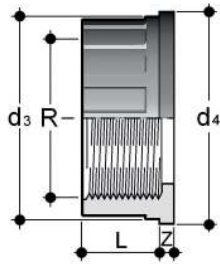

Q/BNC

Union end with NPT female thread

| R | PN | d ₃ | d ₄ | L | Z | g | Code |
|-------|----|----------------|----------------|------|-----|-----|---------|
| 3/8" | 16 | 22 | 24 | 12,7 | 6,3 | 11 | QBNC038 |
| 1/2" | 16 | 27,5 | 30,1 | 17,8 | 5,2 | 17 | QBNC012 |
| 3/4" | 16 | 36 | 38,8 | 18 | 5,2 | 22 | QBNC034 |
| 1" | 16 | 41,5 | 44,7 | 22,6 | 5,7 | 33 | QBNC100 |
| 1"1/4 | 16 | 53 | 56,5 | 25,1 | 7,3 | 61 | QBNC114 |
| 1"1/2 | 16 | 59 | 62,6 | 24,7 | 7 | 77 | QBNC112 |
| 2" | 16 | 74 | 78,4 | 29,6 | 7,8 | 127 | QBNC200 |

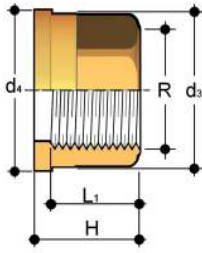

Q/BFO

Union end in brass with female BSP thread

| R | d ₃ | d ₄ | H | L ₁ | g | Code |
|--------|----------------|----------------|------|----------------|-----|---------|
| 3/8" | 22 | 24 | 21,5 | 13,5 | 38 | QBFO038 |
| 1/2" | 27,5 | 30,1 | 22,5 | 16,5 | 60 | QBFO012 |
| 3/4" | 36 | 38,8 | 25,5 | 18,5 | 116 | QBFO034 |
| 1" | 41,5 | 44,7 | 27,5 | 19,5 | 144 | QBFO100 |
| 1 1/4" | 53 | 56,5 | 30,5 | 21,5 | 260 | QBFO114 |
| 1 1/2" | 59 | 62,6 | 33,5 | 23 | 325 | QBFO112 |
| 2" | 74 | 78,4 | 38,5 | 27 | 578 | QBFO200 |

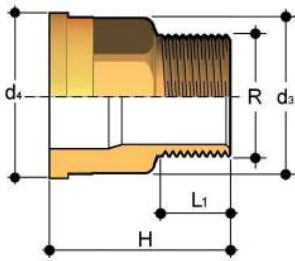

Q/BRO

Union end in brass with male BSP thread

| R | d ₃ | d ₄ | H | L ₁ | g | Code |
|--------|----------------|----------------|------|----------------|-----|---------|
| 3/8" | 22 | 24 | 34,5 | 10,5 | 64 | QBRO038 |
| 1/2" | 27,5 | 30,1 | 39 | 13,5 | 105 | QBRO012 |
| 3/4" | 36 | 38,8 | 43,5 | 15 | 184 | QBRO034 |
| 1" | 41,5 | 44,7 | 48 | 17,5 | 251 | QBRO100 |
| 1 1/4" | 53 | 56,5 | 53 | 19,5 | 437 | QBRO114 |
| 1 1/2" | 59 | 62,6 | 56 | 19,5 | 545 | QBRO112 |
| 2" | 74 | 78,4 | 65,5 | 24 | 937 | QBRO200 |

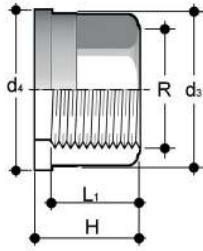

Q/BFX

Union end in A316L stainless steel with female BSP thread

| R | d ₃ | d ₄ | H | L ₁ | g | Code |
|--------|----------------|----------------|------|----------------|-----|---------|
| 3/8" | 22 | 24 | 21,5 | 13,5 | 34 | QBFX038 |
| 1/2" | 27,5 | 30,1 | 22,5 | 16,5 | 54 | QBFX012 |
| 3/4" | 36 | 38,8 | 25,5 | 18,5 | 104 | QBFX034 |
| 1" | 41,5 | 44,7 | 27,5 | 19,5 | 130 | QBFX100 |
| 1 1/4" | 53 | 56,5 | 30,5 | 21,5 | 234 | QBFX114 |
| 1 1/2" | 59 | 62,6 | 33,5 | 23 | 293 | QBFX112 |
| 2" | 74 | 78,4 | 38,5 | 27 | 520 | QBFX200 |

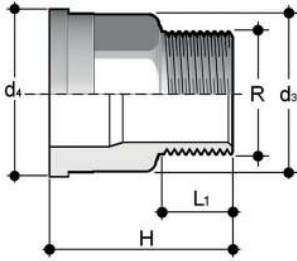

Q/BRX

Union end in A316L stainless steel with male BSP thread

| R | d ₃ | d ₄ | H | L ₁ | g | Code |
|--------|----------------|----------------|------|----------------|-----|---------|
| 3/8" | 22 | 24 | 34,5 | 10,5 | 58 | QBRX038 |
| 1/2" | 27,5 | 30,1 | 39 | 13,5 | 95 | QBRX012 |
| 3/4" | 36 | 38,8 | 43,5 | 15 | 166 | QBRX034 |
| 1" | 41,5 | 44,7 | 48 | 17,5 | 226 | QBRX100 |
| 1 1/4" | 53 | 56,5 | 53 | 19,5 | 393 | QBRX114 |
| 1 1/2" | 59 | 62,6 | 56 | 19,5 | 491 | QBRX112 |
| 2" | 74 | 78,4 | 65,5 | 24 | 843 | QBRX200 |

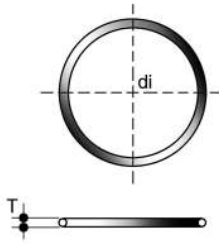

O-RING

O-Ring for union types BIC, BIFC, BIFOC, BIFXC, BIRXC

| Union d | C | di | T | EPDM code | FKM code |
|---------|------|--------|------|-----------|----------|
| 16 | 3062 | 15,54 | 2,62 | OR3062E | OR3062F |
| 20 | 4081 | 20,22 | 3,53 | OR4081E | OR4081F |
| 25 | 4112 | 28,17 | 3,53 | OR4112E | OR4112F |
| 32 | 4131 | 32,93 | 3,53 | OR4131E | OR4131F |
| 40 | 6162 | 40,65 | 5,34 | OR6162E | OR6162F |
| 50 | 6187 | 47 | 5,34 | OR6187E | OR6187F |
| 63 | 6237 | 59,69 | 5,34 | OR6237E | OR6237F |
| 75 | 6300 | 75,57 | 5,34 | OR6300E | OR6300F |
| 90 | 6362 | 91,45 | 5,34 | OR6362E | OR6362F |
| 110 | 6450 | 113,67 | 5,34 | OR6450E | OR6450F |