

 *Aliaxis*



FE DN 40÷200

PVC-U

Butterfly valve

FE DN 40÷200

The FE is a butterfly valve for shutting off or regulating flow, specifically designed for water applications and equipped with a customisable Labelling System.

BUTTERFLY VALVE

- Disk in PVC-U with through shaft
- **Zinc plated square section steel stem completely isolated from the fluid** complying with standard ISO 5211: DN 40 ÷ 65: 11 mm DN 80 ÷ 100: 14 mm DN 125 ÷ 150: 17 mm DN 200: 22 mm
- Can also be installed as a bottom discharge valve or tank dump valve
- **Valve material compatibility** (PVC-U) with water conveyance, drinking water and other food substances according to **current regulations**
- Possibility of directly installing a gearbox or pneumatic and/or electric actuators with a standard drilling pattern according to standard ISO 5211 F05, F07, F10

Technical specifications	
Construction	Bi-directional centric butterfly valve
Size range	DN 40 ÷ 200
Nominal pressure	Wafer version DN 40 ÷ 50: PN 16 with water at 20 °C DN 65÷200: PN 10 with water at 20 °C
Temperature range	0 °C ÷ 60 °C
Reference standards	Flanging system: EN ISO 1452, EN ISO 15493, DIN 2501, ISO 7005-1, EN 1092-1, ANSI B16.5 Cl.150
Riferimenti Reference standards	Construction criteria: EN ISO 16136, EN ISO 1452, EN ISO 15493 Test methods and requirements: ISO 9393 Actuator couplings: ISO 5211
Valve material	Body: PVC-U Disk: PVC-U Stem: Zinc plated carbon steel (C45). On request STAINLESS steel AISI 316
Seal material	Liner: EPDM, FKM. On request NBR
Control options	Hand lever operated; Gearbox, pneumatic actuator, electric actuator

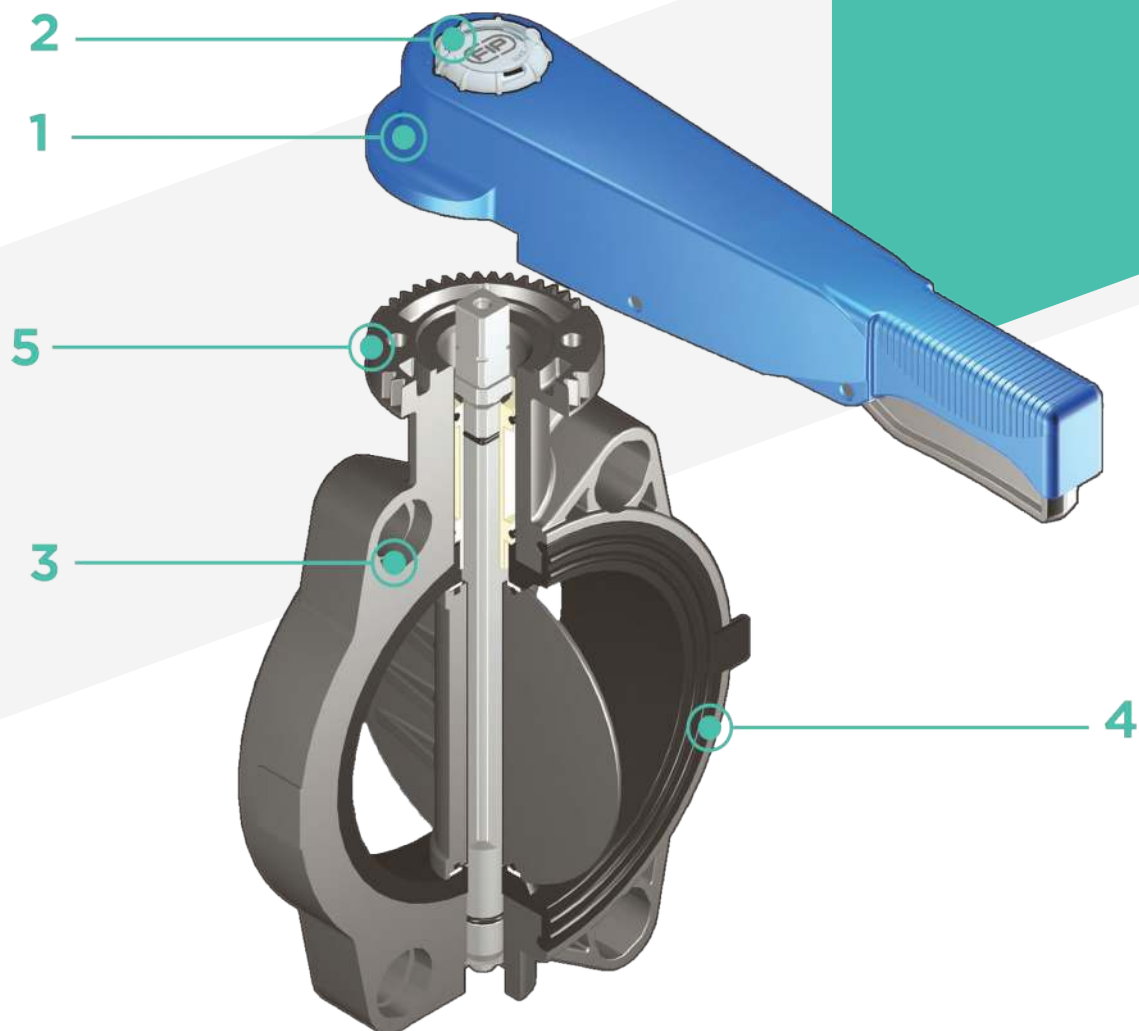

1 Ergonomic multifunctional handle in HIPVC with the option for **quick operation, graduated adjustment** in 12 positions (every 7.5°). 180° reversible mounting

2 Customisable Labelling System: integrated module, made of a transparent protection plug customisable tag holder using the LSE set (available as accessory). **The customisation lets you identify the valve on**

the system according to the specific needs

3 Drilling pattern with oval slots that allow coupling to flanges according to numerous international standards

4 Interchangeable liner with the dual function of forming a hydraulic seal and isolating the body from the fluid.

5 One-piece top flange with PVC-U rack. Drilling according to standard ISO 5211 for direct drive:
 DN 40 ÷ 65: F05
 DN 80 ÷ 150: F07
 DN 200: F10

TECHNICAL DATA

PRESSURE VARIATION ACCORDING TO TEMPERATURE

For water and non-hazardous fluids with regard to which the material is classified as CHEMICALLY RESISTANT. In other cases, a reduction of the nominal pressure PN is required (25 years with safety factor).

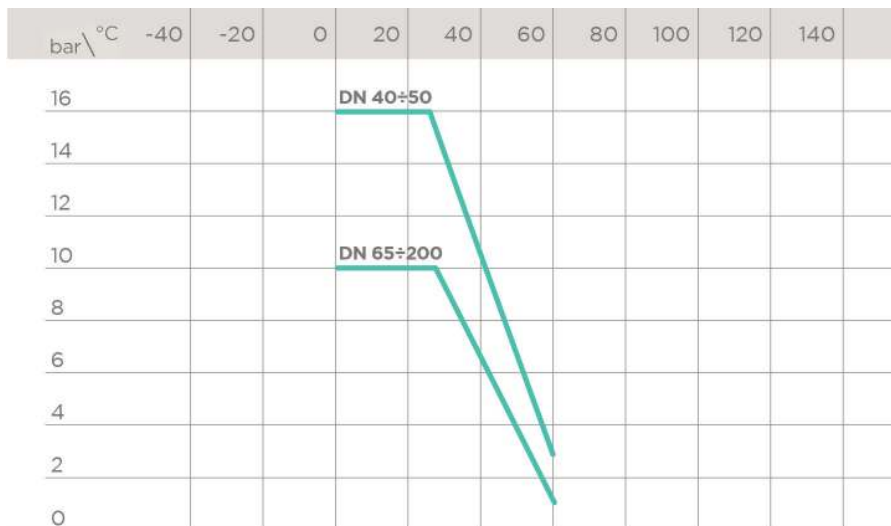

PRESSURE DROP GRAPH

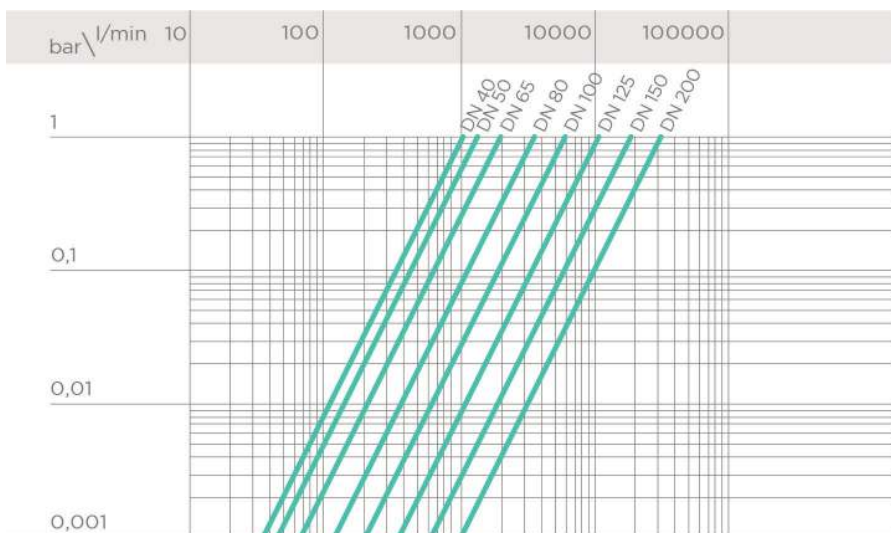

K_v 100 FLOW COEFFICIENT

The K_v100 flow coefficient is the Q flow rate of litres per minute of water at a temperature of 20°C that will generate Δp= 1 bar pressure drop at a certain valve position. The Kv100 values shown in the table are calculated with the valve completely open.

DN	40	50	65	80	100	125	150	200
Kv100 l/min	1000	1285	1700	3550	5900	9850	18700	30500

RELATIVE FLOW COEFFICIENT GRAPH

The relative flow coefficient is the flow rate through the valve as a function of the degree of valve opening.

Horizontal axis: Percentage opening of the disk

Vertical axis: Relative flow coefficient

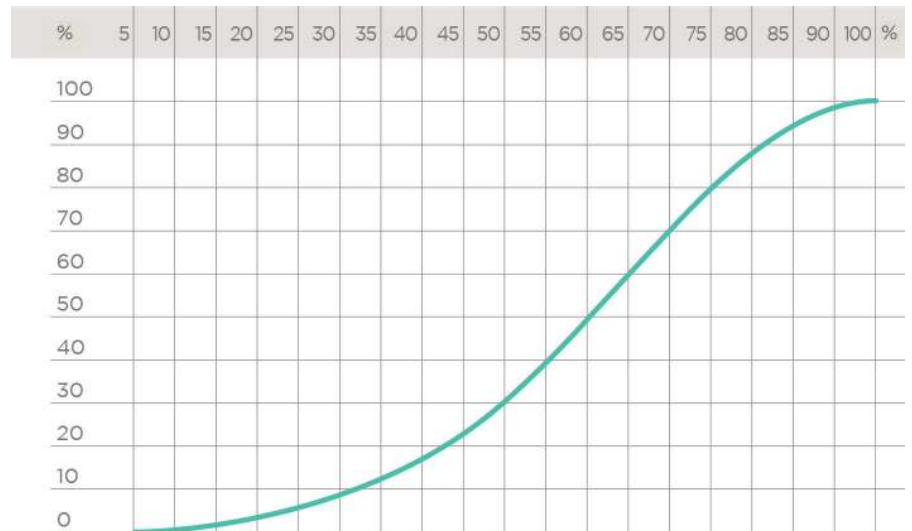

OPERATING TORQUE AT MAXIMUM WORKING PRESSURE

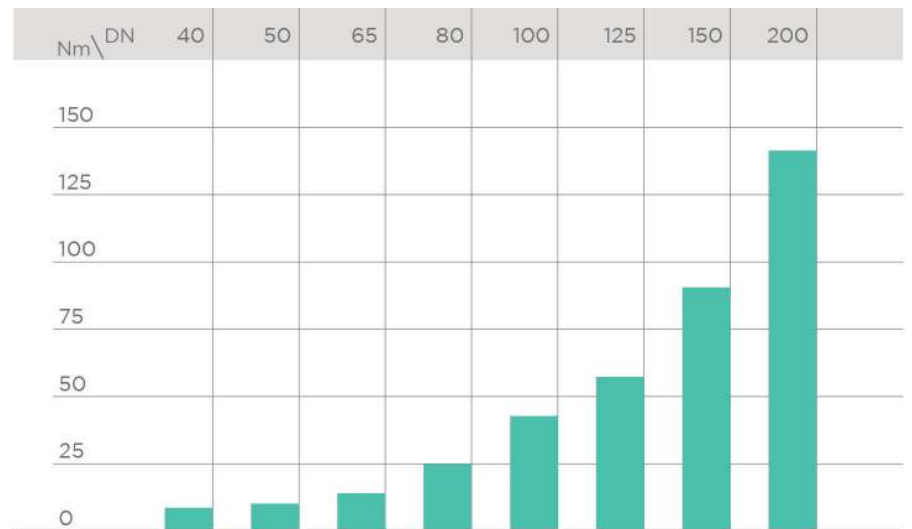

The information in this leaflet is provided in good faith. No liability will be accepted concerning technical data that is not directly covered by recognised international standards. FIP reserves the right to carry out any modification. Products must be installed and maintained by qualified personnel.

DIMENSIONS

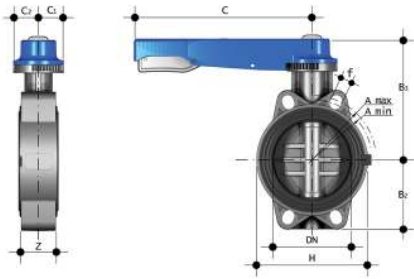

FEOV/LM
Hand operated Butterfly valve

d	DN	PN	A min	A max	B ₂	B ₃	C	C ₁	C ₂	f	H	U	Z	g	EPDM code	FKM code
50 - 1"1/2	40	16	93,5	109	60	136	175	45	42	19	132	4	33	827	FEOVLM050E	FEOVLM050F
63 - 2"	50	16	108	124	70	143	175	45	42	19	147	4	43	1012	FEOVLM063E	FEOVLM063F
75 - 2"1/2	65	10	128	144	80	168	175	45	45	19	165	4	46	1420	FEOVLM075E	FEOVLM075F
90 - 3"	80	10	145	159	90	182	250	45	45	19	130	4	49	1640	FEOVLM090E	FEOVLM090F
110 - 4"	100	10	165	190	105	196	250	45	45	19	150	4	56	1990	FEOVLM110E	FEOVLM110F
*125 - 5"	125	10	204	215	121	215	335	45	45	23	185	4	64	3030	FEOVLM140E	FEOVLM140F
*140 - 5"	125	10	204	215	121	215	335	45	45	23	185	4	64	3030	FEOVLM140E	FEOVLM140F
160 - 6"	150	10	230	242	132	229	335	45	45	23	210	4	70	3730	FEOVLM160E	FEOVLM160F
**200 - 8"	200	10	280	298	161	309	425	65	82	23	325	8	71	8240	FEOVLM225E	FEOVLM225F
**225 - 8"	200	10	280	298	161	309	425	65	82	23	325	8	71	8240	FEOVLM225E	FEOVLM225F

Note: for d75+d225 NBR primary liner available
 * d125, FEOV d140 with special QPV FE-FK d125 for butterfly valve (QPV125FKE)
 ** d200, FEOV d225 with special QPV FE-FK d200 for butterfly valve (QPV200FKE)

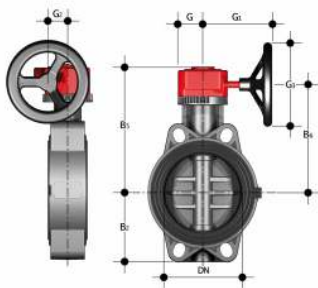

FEOV/RM
Gearbox operated Butterfly valve

d	DN	PN	B ₂	B ₃	B ₆	G	G ₁	G ₂	G ₃	U	g	EPDM code	FKM code
75 - 2"1/2	65	10	80	173	145	48	135	39	125	4	2380	FEOVRM075E	FEOVRM075F
90 - 3"	80	10	90	187	159	48	135	39	125	4	2600	FEOVRM090E	FEOVRM090F
110 - 4"	100	10	105	201	173	48	135	39	125	4	2950	FEOVRM110E	FEOVRM110F
*125 - 5"	125	10	121	220	192	48	144	39	200	4	4400	FEOVRM140E	FEOVRM140F
*140 - 5"	125	10	121	220	192	48	144	39	200	4	4400	FEOVRM140E	FEOVRM140F
160 - 6"	150	10	132	235	207	48	144	39	200	4	5100	FEOVRM160E	FEOVRM160F
**200 - 8"	200	10	161	288	257	65	175	60	200	8	9260	FEOVRM225E	FEOVRM225F
**225 - 8"	200	10	161	288	257	65	175	60	200	8	9260	FEOVRM225E	FEOVRM225F

Note: for d75+d225 NBR primary liner available
 * d125, FEOV d140 with special QPV FE-FK d125 for butterfly valve (QPV125FKE)
 ** d200, FEOV d225 with special QPV FE-FK d200 for butterfly valve (QPV200FKE)

ACCESSORIES



LSE

Customisation and label printing set for Easyfit handle made up of pre-cut adhesive sheets and software for guided label creation.

d	DN	total labels	N° of sheets	FE*- FK* code
50	40	500	10	LSE040
63	50	500	10	LSE040
75	65	500	10	LSE040
90	80	500	10	LSE040
110	100	500	10	LSE040
125-140	125	500	10	LSE040
160	150	500	10	LSE040
200-225	200	500	10	LSE040

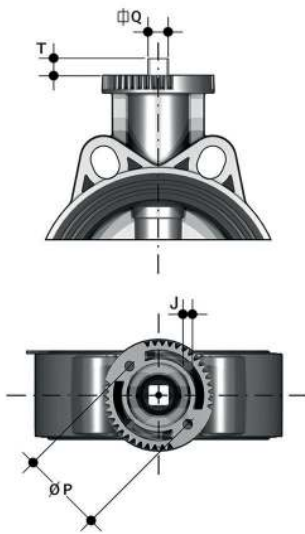

ACTUATOR MOUNTING FLANGE

The valve can be equipped with standard pneumatic or electric actuators and gearbox for heavy-duty operations, using a flange in PP-GR reproducing the drilling pattern provided for by standard ISO 5211.

DN	J	P	Φ	T	Q
40	7	50	F 05	12	11
50	7	50	F 05	12	11
65	7	50	F 05	12	11
80	9	70	F 07	16	14
100	9	70	F 07	16	14
125	9	70	F 07	19	17
150	9	70	F 07	19	17
200	11	102	F 10	24	22

CUSTOMISATION

Fig. 1



Fig. 2

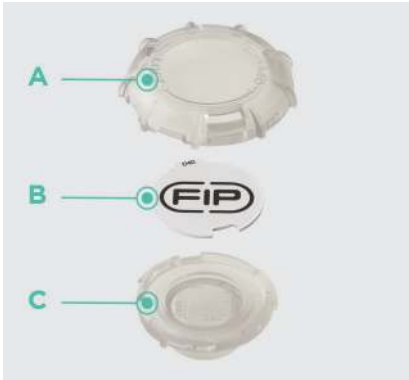

The FE valve is equipped with the customisable Labelling System.

This system lets you create special labels to insert in the handle. This makes it extremely easy to apply company logos, identification serial numbers or service information such as, for example, the valve function in the system, the transported fluid, but also specific information for customer service, such as the customer name or installation date or location on the valves.

The specific LCE module is a standard supply and is made up of a rigid transparent water-resistant PVC plug (A-C) and white tag holder (B) made of the same material, one side of which bears the FIP logo (fig. 1).

The tag holder, inserted in the plug, can be removed and, once overturned, used for customisation by applying labels printed with the software supplied with the LSE set.

Proceed as follows to apply the label on the valve:

- 1) Remove the upper part of the transparent plug (A) rotating it counter-clockwise as indicated by the word "Open" on the plug and remove it.
- 2) Extract the tag holder from its housing on the lower part of the plug (C)
- 3) Apply the adhesive label on the holder (B) to align the profiles matching the tab position.
- 4) Reinsert the tag holder in its housing at the bottom of the plug
- 5) Reposition the top of the plug in the housing rotating it clockwise; this way the label is protected against the elements.

COMPONENTS

EXPLODED VIEW DN 40÷65

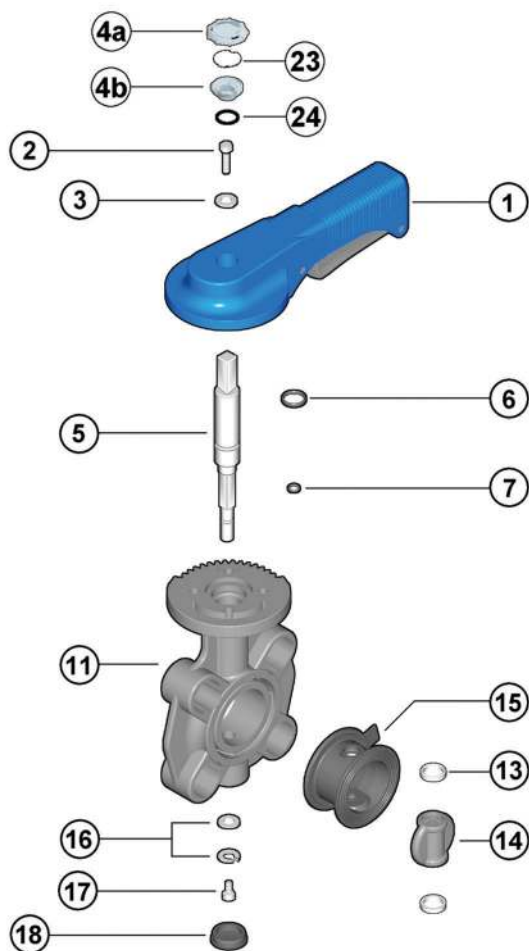

- | | | | | | |
|-------------|---------------------------------------|-----------|-------------------------------|-----------|-----------------------------|
| 1 | Handle (HIPVC - 1) | 6 | Stem O-Ring (EPDM or FKM - 1) | 16 | Washer (Steel - 1) |
| 2 | Screw (STAINLESS steel - 1) | 7 | Stem O-Ring (EPDM or FKM - 1) | 17 | Screw (STAINLESS steel - 1) |
| 3 | Washer (STAINLESS steel - 1) | 11 | Body (PVC-U - 1) | 18 | Protection plug (PE - 1) |
| 4a/b | Transparent protection plug (PVC - 1) | 13 | Anti-friction ring (PTFE - 2) | 23 | Tag holder (PVC-U - 1) |
| 5 | Stem (Zinc plated steel - 1) | 14 | Disk (PVC-U - 1) | 24 | O-Ring (NBR - 2) |
| | | 15 | Liner (EPDM o FKM - 1) | | |

The material of the component and the quantity supplied are indicated between brackets

EXPLODED VIEW DN 80÷200

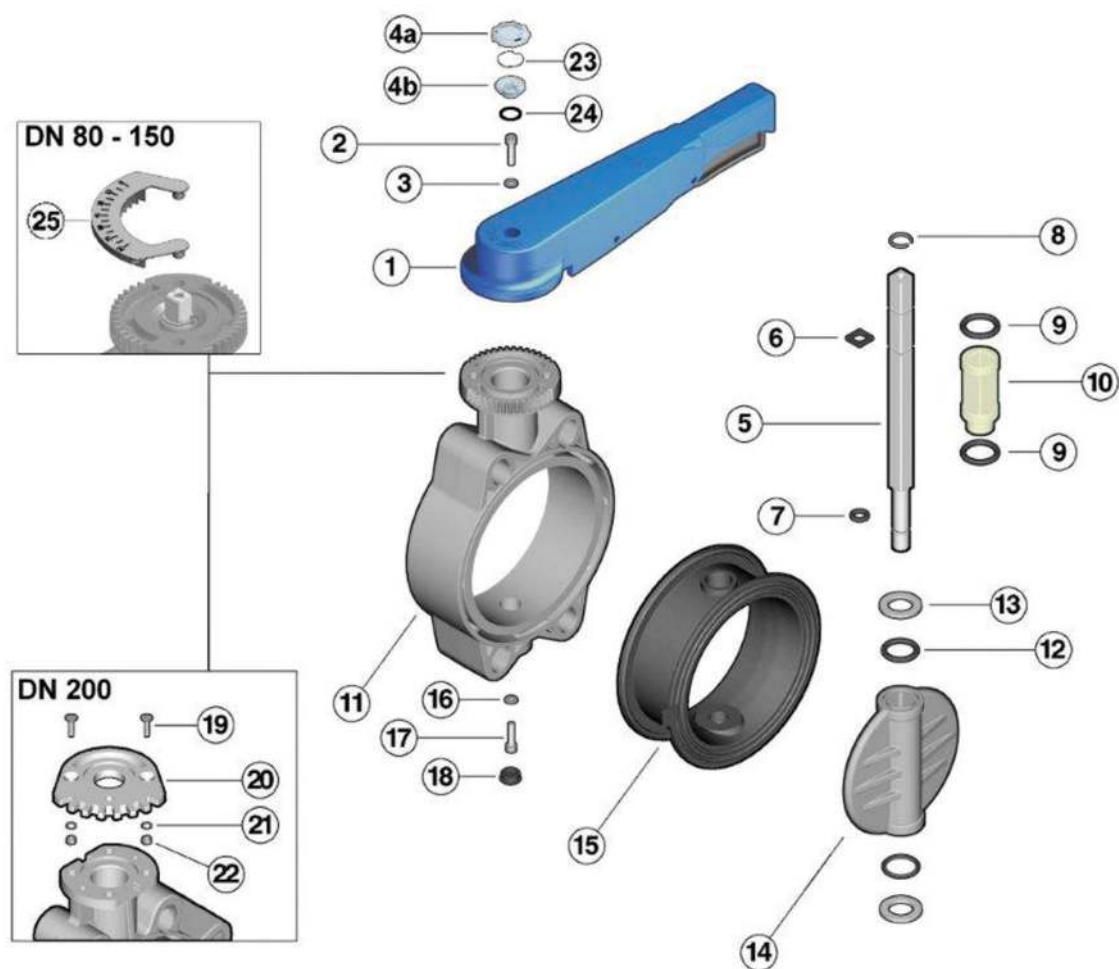

- | | | | | | |
|-------------|---------------------------------------|-----------|-------------------------------|-----------|-------------------------------|
| 1 | Handle (HIPVC - 1) | 9 | Bush O-Ring (EPDM or FKM - 2) | 17 | Screw (STAINLESS steel - 1) |
| 2 | Screw (STAINLESS steel - 1) | 10 | Bush (Nylon - 1) | 18 | Protection plug (PE - 1) |
| 3 | Washer (STAINLESS steel - 1) | 11 | Body (PVC-U - 1) | 19 | Screw (STAINLESS steel - 2) |
| 4a/b | Transparent protection plug (PVC - 1) | 12 | Disk O-Ring (EPDM or FKM - 2) | 20 | Plate (PVC-U - 1) |
| 5 | Stem (Zinc plated steel - 1) | 13 | Anti-friction ring (PTFE - 2) | 21 | Washer (STAINLESS steel - 2) |
| 6 | Stem O-Ring (EPDM or FKM - 1) | 14 | Disk (PVC-U - 1) | 22 | Nut (STAINLESS steel - 2) |
| 7 | Stem O-Ring (EPDM or FKM - 1) | 15 | Liner (EPDM o FKM - 1) | 23 | Tag holder (PVC-U - 1) |
| 8 | Seeger ring (STAINLESS steel - 2) | 16 | Washer (Steel - 1) | 24 | O-Ring (NBR - 2) |
| | | | | 25 | Position indicator (PVC-U- 1) |

The material of the component and the quantity supplied are indicated between brackets

DISASSEMBLY

- 1) Remove the LCE module consisting of the rigid transparent PVC plug (4a-4b) and white tag holder (23) and remove screw (2) and washer (3).
- 2) Remove the handle (1).
- 3) Remove the protection plug (18) and screw (17) with the washer (16).
- 4) Extract the stem (5) and disk (14).
- 5) Remove the liner (15) from the body (11).
- 6) Remove the Seeger ring (8) and guide bush (10).
- 7) Remove O-rings (6) and (7).

ASSEMBLY

- 1) Place the liner (15) on the body (11).
- 2) Insert O-rings (6) and (7) on the stem (5).
- 3) Insert the gaskets (9) on the guide bush (10) and the bush on the stem. Lock the bush using the Seeger ring (8).
- 4) Position the O-rings (12) and then the anti-friction rings (13) on the disk (14) and the disk inside the body, after having lubricated the liner (15).
- 5) Insert the stem (5) through the body (11) and disk (14).
- 6) Tighten screw (17) with washer (16) and insert the protection plug (18).
- 7) Position the handle (1) on the stem.
- 8) Tighten screw (2) with washer (3) and replace the LCE module consisting of the rigid transparent PVC plug (4a-4b) and white tag holder protection(23).



Note: during assembly operations, it is advisable to lubricate the rubber seals. Mineral oils are not recommended for this task as they react aggressively with EPDM rubber.

INSTALLATION

JOINTS

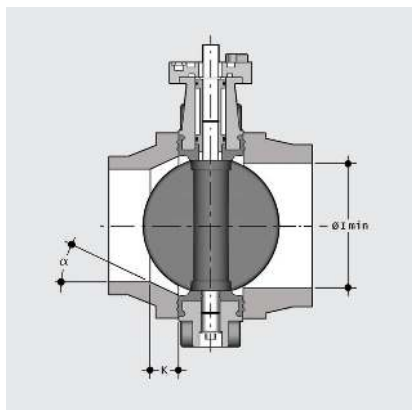

Before proceeding with the installation of the stubs, check that the bore of the fittings has sufficient clearance to allow the valve disk to open correctly. Also check the maximum coupling distance for the liner. Before proceeding with the installation of the FE valve, check that the bore of the stubs allows the correct opening of the disk

DN	I min.
40	25
50	28
65	47
80	64
100	84
125	108
150	134
200	187

PVC-U STUBS

To install on PVC-U stubs, check the valve-stub-flange couplings in the following table.

d	DN	50	63	75	90	110	125	140	160	200	225
		40	50	65	80	100	100	125	150	200	200
50	40										
63	50										
75	65										
90	80										
110	100										
140	125						*				
160	150										
225	200									**	

Stub with female end for solvent welding according to EN ISO 1452 and DIN 8063- 4

* With special stub d125 DN 125 for FE d140 DN 125 and flange d140 DN 125

** With special stub d200 DN 200 for FE d225 DN 200 and flange d225 DN 200

PP-PE STUBS

For the installation of PP-PE stubs, for butt welding a short spigot or electrofusion/butt welding a long spigot, check the valve-stub couplings and the K - a chamfer dimensions where necessary according to the different SDR's in the following table.

	d	DN	50	63	75	90	110	125	140	160	180	200	225	250	280	315
			40	50	65	80	100	100	125	150	150	200	200	250	250	300
FE	50	40														
	63	50														
	75	65														
	90	80														
	110	100														
	140	125														
	160	150														
	225	200														
SDR		17/17,6										k=26,5 a=20°		k=15,7 a=25°		k=13,3 a=25°
		11								k=35 a=20°		k=35 a=25°	k=40 a=15°	k=32,5 a=25°	k=35 a=25°	k=34,5 a=25°
		7,4			k=10 a=35°	k=15 a=35°		k=20 a=30°	k=35 a=20°	k=15 a=35°	k=40 a=20°	k=35 a=30°	k=55 a=30°	k=35 a=30°	k=65 a=30°	

Short/long spigot stubs according to EN ISO 15494 and DIN 16962/16963 and flange

TIGHTENING THE STUD-BOLTS

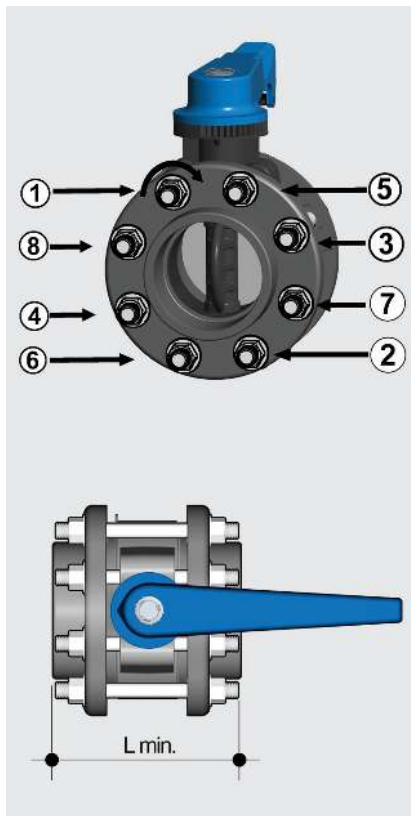

Before tightening the stud-bolts, it is advisable to open the disk in order to prevent damage to the seal. Tighten the stud-bolts in a uniform manner, in the order indicated in the figure, to the operating torque value indicated in the table. The stud-bolts do not need to be excessively tightened in order to produce a perfect hydraulic seal.

Overtightening could adversely affect the operating torque of the valve

DN	L min.	*Nm
40	M16 x150	9
50	M16 x150	12
65	M16 x170	15
80	M16 x180	18
100	M16 x180	20
125	M16 x210	35
150	M20 x 240	40
200	M20 x 260	55

* Tightening torques for nuts and bolts on couplings with backing ring.

Values required to obtain the hydraulic test (1.5xPN at 20°C)
(new or lubricated nuts and bolts)

WARNINGS

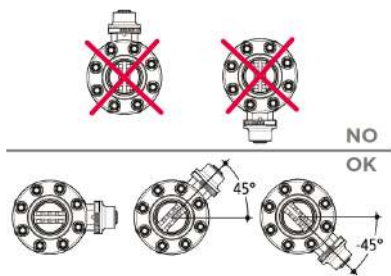

Make sure that the valves installed on the system are suitably supported for their weight.

Always avoid sudden closing manoeuvres and protect the valve from accidental manoeuvres. To this end, it is advisable to install a reduction gear, available on request.

In the case of dirty fluids or those with sediments, install the valve inclined as shown in the figure.