



## DKB/CP DN 15÷65

PVC-U/PVC-C/PP-H

PNEUMATICALLY ACTUATED PN6 2-WAY DIAPHRAGM  
VALVE FOR LIMITED PRESSURE APPLICATIONS



# DKB/CP DN 15÷65

The new DKB/CP diaphragm valve is the proper solution for non-severe operating conditions that, however, require reliability and a long working life. The new internal geometry of the body optimises the fluid dynamic efficiency by increasing the flow rate and ensuring an optimum linearity of the flow adjustment curve. The DKB/CP is extremely compact and very light.

## PNEUMATICALLY ACTUATED PN6 2-WAY DIAPHRAGM VALVE FOR LIMITED PRESSURE APPLICATIONS

- Connection system for solvent weld, threaded and flanged joints
- **Optimised fluid dynamic design:** maximum output flow rate thanks to the optimised efficiency of the fluid dynamics that characterise the new internal geometry of the body
- Bonnet fastening screws in STAINLESS steel protected against the external environment by PE plugs. Absence of metal parts exposed to the external environment to prevent any risk of corrosion
- New flanged bodies: the new bodies, characterised by a monolithic flanged structure, are available in PVC-U, PVC-C and PP-H materials. This design, free of joints between body and flanges, considerably reduces mechanical stress and increases system performance
- **CDSA seal system** (Circular Diaphragm Sealing Angle) with a uniform distribution of the shutter pressure on the sealing membrane offers the following advantages:
  - Operating torque reduction.
  - Reduced mechanical stress on all valve components (actuator, body and diaphragm).
  - Low risk of the accumulation of deposits, contamination or damage to the diaphragm due to crystallisation.
  - Easy to clean valve interior.

Technical specifications - DKB	
<b>Construction</b>	Pneumatically actuated diaphragm valve with body at maximized flow rate
<b>Size range</b>	DN 15 ÷ 65
<b>Nominal pressure</b>	PN 6 with water at 20° C
<b>Temperature range</b>	<b>PVC-U:</b> 0 °C ÷ 60 °C <b>PVC-C:</b> 0° C ÷ 100° C <b>PP-H:</b> 0° C ÷ 100° C
<b>PVC-U coupling standards</b>	<b>Solvent welding:</b> EN ISO 1452, EN ISO 15493, EN ISO 10931, BS 4346-1, DIN 8063, NF T54-028, ASTM D 2467, ASTM F 439. Can be coupled to pipes according to EN ISO 1452, EN ISO 15493, EN ISO 15494, ISO 10931, DIN 8062, NF T54-016, ASTM D 1785, ASTM F 441 <b>Thread:</b> ISO 228-1, DIN 2999, ASTM D 2464. <b>Flanging system:</b> ISO 7005-1, EN ISO 1452, EN ISO 15493, EN 1092-1, EN ISO 15494, EN ISO 10931, EN 558-1, DIN 2501, ANSI B.16.5 cl. 150, JIS B 2220.
<b>PVC-C coupling standards</b>	<b>Solvent welding:</b> EN ISO 15493, ASTM F 439. Can be coupled to pipes according to EN ISO 15493, ASTM F 441. <b>Thread:</b> ISO 228-1, DIN 2999. <b>Flanging system:</b> ISO 7005-1, EN ISO 15493, EN 558-1, DIN 2501, ANSI B.16.5 cl.150
<b>PP-H coupling standards</b>	<b>Welding:</b> EN ISO 15494. Can be coupled to pipes according to EN ISO 15494. <b>Thread:</b> ISO 228-1, DIN 2999. <b>Flanging system:</b> ISO 7005-1, EN ISO 1092-1, EN 15494, EN 558-1, DIN 2501, ANSI B16.5 cl.150
<b>Reference standards</b>	<b>PVC-U construction criteria:</b> EN ISO 16138, EN ISO 1452, EN ISO 15493 <b>PVC-C construction criteria:</b> EN ISO 16138, EN ISO 15493 <b>PP-H construction criteria:</b> EN ISO 16138, EN ISO 15494 <b>Test methods and requirements:</b> ISO 9393 <b>PVC-U/PVC-C installation criteria:</b> DVS 2204, DVS 2221, UNI 11242 <b>PP-H installation criteria:</b> DVS 2202-1, DVS 2207-11, DVS 2208-1, UNI 11318
<b>Valve material</b>	PVC-U / PVC-C / PP-H
<b>Seal material</b>	EPDM
<b>Control options</b>	Pneumatic actuator

The new DKB/CP diaphragm valve has a piston actuator in PP-GR with a simplified design, ensuring essential performance.

Technical specifications - Pneumatic actuator	
<b>Construction</b>	Single-acting (NC) pneumatic piston actuator
<b>Actuator material</b>	<b>Body and bonnet:</b> PP-GR
<b>Control air pressure</b>	<b>Minimum:</b> according to working pressure and actuator function (see graphs) <b>Maximum:</b> 6 bar
<b>Power supply</b>	Dry or lubricated filtered compressed air. If using other fluids, contact the FIP service centre
<b>Control fluid temperature</b>	Max 40 °C
<b>Temperature range</b>	-20 °C ÷ 50 °C
<b>Accessories</b>	<ul style="list-style-type: none"> <li>• Pilot solenoid valves 3-5/2 ways for direct or manifold mounting</li> <li>• Distance plate</li> </ul>

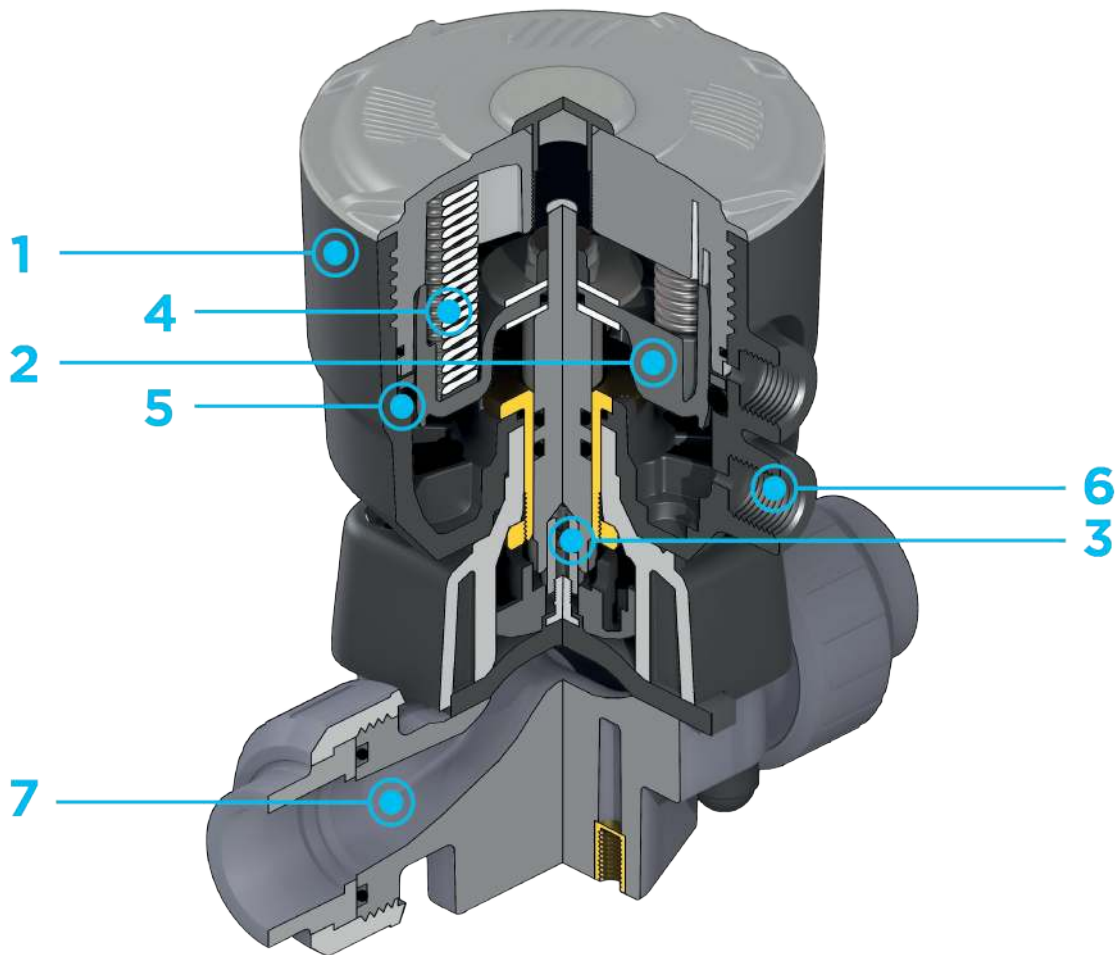

**1** **Compact and light piston in PP-GR**, ideal for heavy-duty applications in chemically aggressive environments with a **diaphragm perimeter containment system** that ensures the perfect compression of the rubber without any lateral expansion.

**2** **Piston in high strength IXEF®**. The high quality finishing of the external surface guarantees perfect slidability over the seal and ensures a long working life without any actuator maintenance.

**3** High strength **stainless steel stem** with double seal O-Ring. **Floating pin connection** between the actuator stem and diaphragm to prevent concentrated loads, improve the seal and extend its lifetime.

**4** Actuator equipped with 4 independent **cartridge springs** arranged radially to uniformly distribute the load on the piston.

**5** **Dual function main gasket**. **Piston seal**: the gasket does not move but sits securely on the actuator cylinder instead of the piston. **External seal**: the gasket positioned above the threaded joint between the bonnet and cylinder ensures that the coupling is not stressed by the pressure inside the actuator.

**6** Easy installation in confined spaces: **compressed air inlets with G 1/4" threaded adjustable connections** to enable alignment with the piping. PP-GR connections prevent any risk of corrosion.

**7** **New valve body internal design**. **Substantially higher flow coefficient** and lower pressure drops. The degree of efficiency reached has also enabled the **size and weight of the valve to be reduced**. **Adjustment linearity**: the internal profiles of the valve greatly improve its characteristic curve, allowing **extremely sensitive and precise adjustment** along the entire length of the shutter stroke.

# TECHNICAL DATA

## PRESSURE VARIATION ACCORDING TO TEMPERATURE

### PVC-U BODY

For water and non-hazardous fluids with regard to which the material is classified as CHEMICALLY RESISTANT. In other cases, a reduction of the nominal pressure PN is required (25 years with safety factor).



### PVC-C BODY

For water and non-hazardous fluids with regard to which the material is classified as CHEMICALLY RESISTANT. In other cases, a reduction of the nominal pressure PN is required (25 years with safety factor).



### PP-H BODY

For water and non-hazardous fluids with regard to which the material is classified as CHEMICALLY RESISTANT. In other cases, a reduction of the nominal pressure PN is required (25 years with safety factor).



## PRESSURE DROP GRAPH

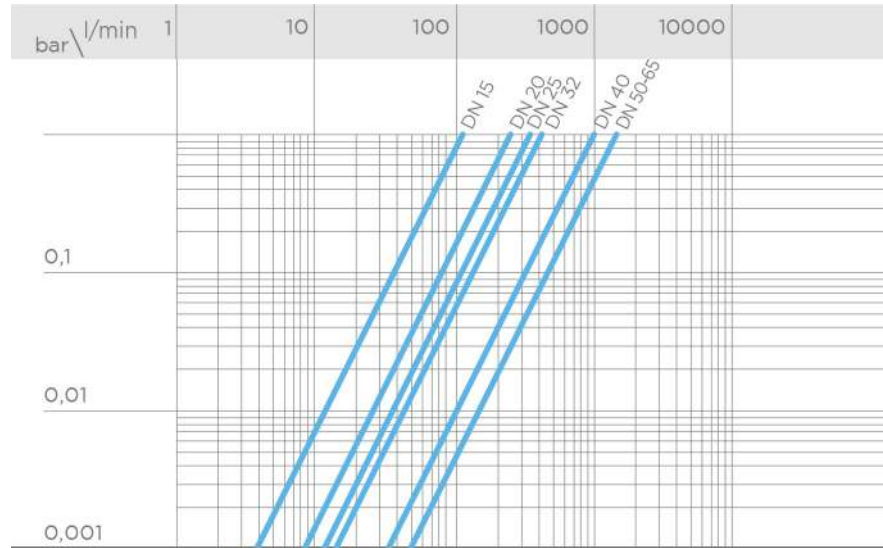

## K<sub>v</sub>100 FLOW COEFFICIENT

The K<sub>v</sub>100 flow coefficient is the Q flow of litres per minute of water at a temperature of 20°C that will generate Δp= 1 bar pressure drop at a certain valve position.

The K<sub>v</sub>100 values shown in the table are calculated with the valve completely open.

DN	15	20	25	32	40	50	65
Kv100 l/min	112	261	445	550	1087	1648	1600

## RELATIVE FLOW COEFFICIENT GRAPH

The relative flow coefficient is the flow rate through the valve as a function of the degree of valve opening.

X axis: Opening percentage of the diaphragm

Y axis: Relative flow coefficient

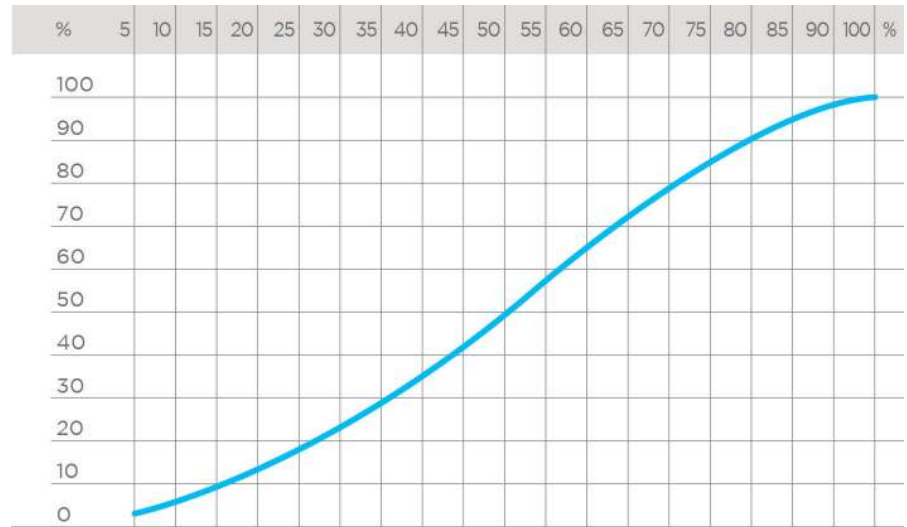

## CONTROL PRESSURE ACCORDING TO DKB/ CP NC WORKING PRESSURE

Minimum control pressure according  
to working pressure with EPDM/FKM  
diaphragm

X axis: Working pressure

Y axis: Control pressure

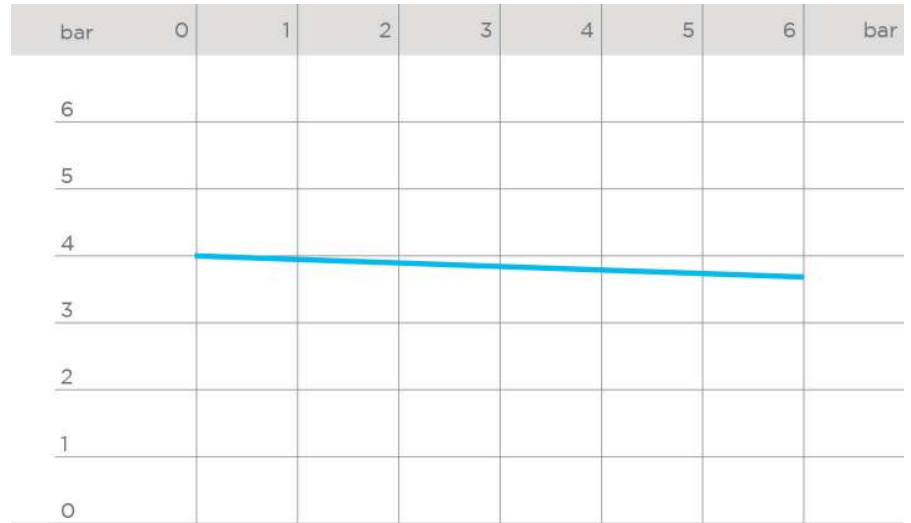

# PNEUMATIC ACTUATOR DATA

## FUNCTIONAL CHARACTERISTICS

		Single-acting (SA)
Function type		normally closed (NC)
Valve opening		air
Valve closing		spring

## ACTUATOR CAPACITY

L: litre, equivalent to  $10^{-3} \text{ m}^3$   
 Air consumption in normal litres (or normal cubic metres) per operating cycle can be calculated by correcting according to operating conditions such as control air pressure.

DN	15 ÷ 32	40	50 ÷ 65
NC	0.12 L	0.4 L	0.64 L

## COMPRESSED AIR CONNECTIONS

Function type	Normally closed (NC)
Valve opening	Inlet B

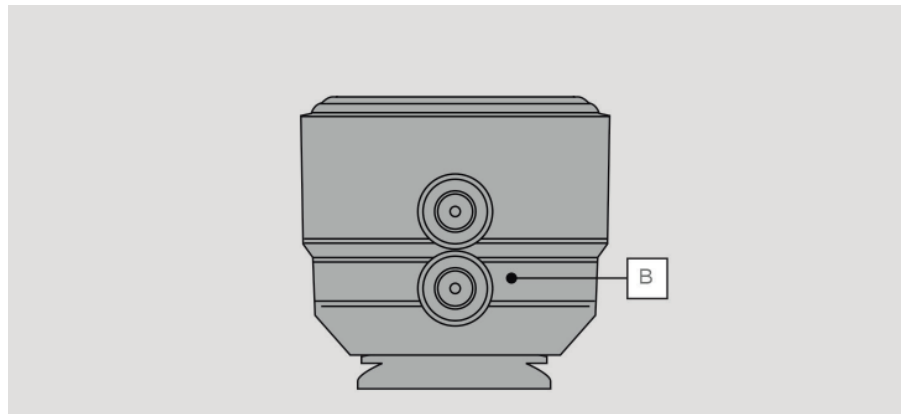



# DIMENSIONS

## DKB/CP DN 15÷65 PVC-U

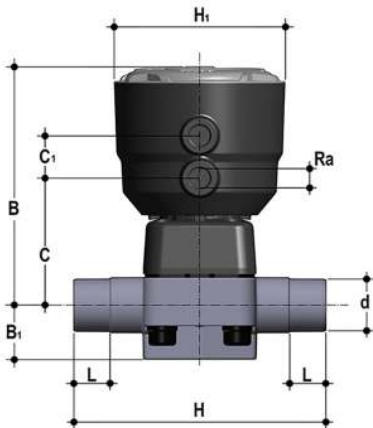

### DKBDV/CP NC

Pneumatically actuated diaphragm valve with male ends, metric series Normally Closed function

d	DN	PN	B	B <sub>1</sub>	C	C <sub>1</sub>	H	H <sub>1</sub>	L	R <sub>0</sub>	g	EPDM Code
20	15	6	134	25	66	24	124	97	16	1/4"	645	DKBDVNC020E
25	20	6	137	30	69	24	144	97	19	1/4"	667	DKBDVNC025E
32	25	6	145	33	78	24	154	97	22	1/4"	867	DKBDVNC032E
40	32	6	149	30	82	24	174	97	26	1/4"	911	DKBDVNC040E
50	40	6	193	35	112	24	194	126	31	1/4"	2502	DKBDVNC050E
63	50	6	231	46	142	24	224	157	38	1/4"	5598	DKBDVNC063E
75	65	6	231	46	142	24	284	157	44	1/4"	5770	DKBDVNC075E

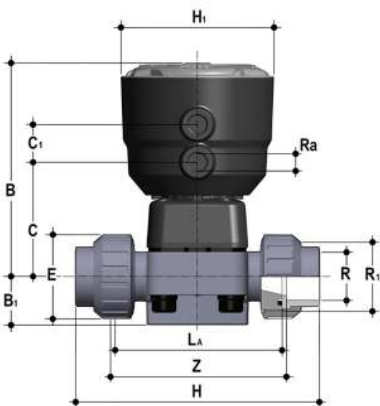

### DKBUIV/CP NC

Pneumatically actuated diaphragm valve with female union ends, metric series. Normally Closed function

d	DN	PN	B	B <sub>1</sub>	C	C <sub>1</sub>	E	H	H <sub>1</sub>	L <sub>0</sub>	R <sub>1</sub>	R <sub>0</sub>	Z	g	EPDM Code
20	15	6	134	25	66	24	41	129	97	90	1"	1/4"	100	685	DKBUIVNC020E
25	20	6	137	30	69	24	50	154	97	108	1"1/4	1/4"	116	747	DKBUIVNC025E
32	25	6	145	33	78	24	58	168	97	116	1"1/2	1/4"	124	975	DKBUIVNC032E
40	32	6	149	30	82	24	72	192	97	134	2"	1/4"	140	1101	DKBUIVNC040E
50	40	6	193	35	112	24	79	222	126	154	2"1/4	1/4"	160	2722	DKBUIVNC050E
63	50	6	231	46	142	24	98	266	157	184	2"3/4	1/4"	190	5984	DKBUIVNC063E

# DIMENSIONS

## DKB/CP DN 15÷65 PVC-U

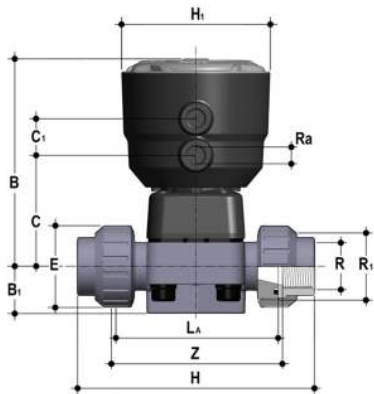

### DKBUFV/CP NC

Pneumatically actuated diaphragm valve with BSP threaded female union ends. Normally Closed function

R	DN	PN	B	B <sub>1</sub>	C	C <sub>1</sub>	E	H	H <sub>1</sub>	L <sub>o</sub>	R <sub>1</sub>	R <sub>o</sub>	Z	g	EPDM Code
1/2"	15	6	134	25	66	24	41	131	97	90	1"	1/4"	97	685	DKBUFVNC012E
3/4"	20	6	137	30	69	24	50	151	97	108	1"1/4	1/4"	118	747	DKBUFVNC034E
1"	25	6	145	33	78	24	58	165	97	116	1"1/2	1/4"	127	975	DKBUFVNC100E
1"1/4	32	6	149	30	82	24	72	188	97	134	2"	1/4"	145	1101	DKBUFVNC114E
1"1/2	40	6	193	35	112	24	79	208	126	154	2"1/2	1/4"	165	2722	DKBUFVNC112E
2"	50	6	231	46	142	24	98	246	157	184	2"3/4	1/4"	195	5984	DKBUFVNC200E

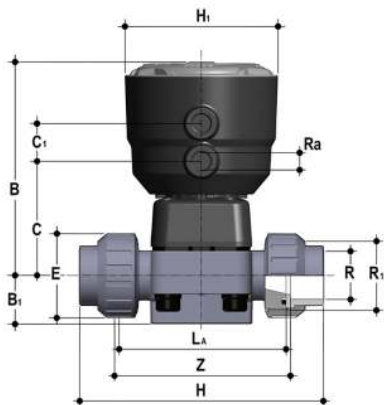

### DKBUAV/CP NC

Pneumatically actuated diaphragm valve with female union ends for solvent welding, ASTM series Normally Closed function

R	DN	PN	B	B <sub>1</sub>	C	C <sub>1</sub>	E	H	H <sub>1</sub>	L <sub>o</sub>	R <sub>1</sub>	R <sub>o</sub>	Z	g	EPDM Code
1/2"	15	6	134	25	66	24	41	143	97	90	1"	1/4"	98	685	DKBUAVNC012E
3/4"	20	6	137	30	69	24	50	167	97	108	1"1/4	1/4"	115	747	DKBUAVNC034E
1"	25	6	145	33	78	24	58	180	97	116	1"1/2	1/4"	122	975	DKBUAVNC100E
1"1/4	32	6	149	30	82	24	72	208	97	134	2"	1/4"	144	1101	DKBUAVNC114E
1"1/2	40	6	193	35	112	24	79	234	126	154	2"1/2	1/4"	164	2722	DKBUAVNC112E
2"	50	6	231	46	142	24	98	272	157	184	2"3/4	1/4"	195	5984	DKBUAVNC200E

# DIMENSIONS

## DKB/CP DN 15÷65 PVC-U

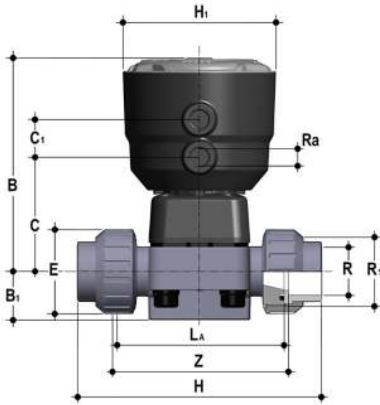

### DKBULV/CP NC

Pneumatically actuated diaphragm valve with female union ends for solvent welding, BS series  
Normally Closed function

d	DN	PN	B	B <sub>1</sub>	C	C <sub>1</sub>	E	H	H <sub>1</sub>	L <sub>2</sub>	R <sub>1</sub>	R <sub>2</sub>	Z	g	EPDM Code
1/2"	15	6	134	25	66	24	41	131	97	90	1"	1/4"	97	685	DKBULVNC012E
3/4"	20	6	137	30	69	24	50	154	97	108	1"1/4	1/4"	116	747	DKBULVNC034E
1"	25	6	145	33	78	24	58	166	97	116	1"1/2	1/4"	121	975	DKBULVNC100E
1"1/4	32	6	149	30	82	24	72	194	97	134	2"	1/4"	142	1101	DKBULVNC114E
1"1/2	40	6	193	35	112	24	79	222	126	154	2"1/4	1/4"	162	2722	DKBULVNC112E
2"	50	6	231	46	142	24	98	266	157	184	2"3/4	1/4"	194	5984	DKBULVNC200E

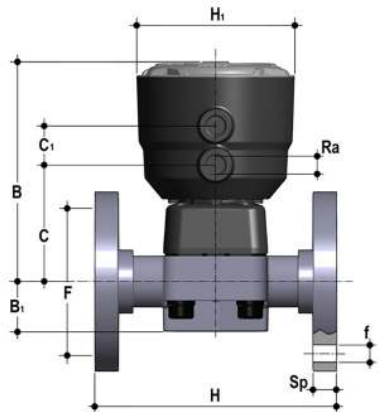

### DKBOV/CP NC

Pneumatically actuated diaphragm valve with monolithic flanged body, drilled PN10/16. Face to face according to EN 558-1. Normally Closed function

d	DN	PN	B	B <sub>1</sub>	C	C <sub>1</sub>	F	f	H	H <sub>1</sub>	R <sub>2</sub>	U	Sp	g	EPDM Code
20	15	6	134	25	66	24	65	14	130	97	1/4"	4	13.5	875	DKBOVNC020E
25	20	6	137	30	69	24	75	14	150	97	1/4"	4	13.5	955	DKBOVNC025E
32	25	6	145	33	78	24	85	14	160	97	1/4"	4	13.5	1221	DKBOVNC032E
40	32	6	149	30	82	24	100	18	180	97	1/4"	4	14	1411	DKBOVNC040E
50	40	6	193	35	112	24	110	18	200	126	1/4"	4	16	3136	DKBOVNC050E
63	50	6	231	46	142	24	125	18	230	157	1/4"	4	16	6351	DKBOVNC063E
75	65	6	231	46	142	24	145	18	290	157	1/4"	4	21	6952	DKBOVNC075E

# DIMENSIONS

## DKB/CP DN 15÷65 PVC-U

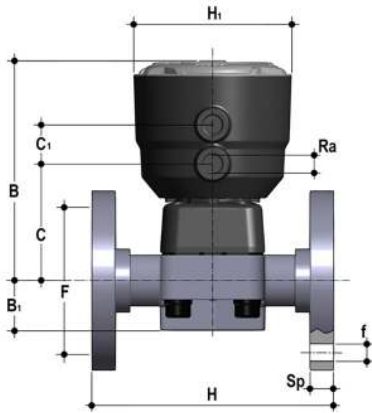

### DKBOAV/CP NC

Pneumatically actuated diaphragm valve with monolithic flanged body, drilled ANSI B16.5 cl. 150 #FF. Normally Closed function

d	DN	PN	B	B <sub>1</sub>	C	C <sub>1</sub>	F	f	H	H <sub>1</sub>	R <sub>3</sub>	U	Sp	g	EPDM Code
1/2"	15	6	134	25	66	24	60.30	14	108	97	1/4"	4	13.5	875	DKBOAVNC012E
3/4"	20	6	137	30	69	24	69.90	15.7	120	97	1/4"	4	13.5	955	DKBOAVNC034E
1"	25	6	145	33	78	24	79.40	15.7	131	97	1/4"	4	13.5	1221	DKBOAVNC100E
1" 1/4	32	6	149	30	82	24	88.90	15.7	162	97	1/4"	4	14	1411	DKBOAVNC114E
1" 1/2	40	6	193	35	112	24	98.40	15.7	180	126	1/4"	4	16	3136	DKBOAVNC112E
2"	50	6	231	46	142	24	120.70	19	210	157	1/4"	4	16	6351	DKBOAVNC200E
2" 1/2	65	6	231	46	142	24	139.70	19	250	157	1/4"	4	21	6952	DKBOAVNC212E

# DIMENSIONS

## DKB/CP DN 15÷65 PVC-C

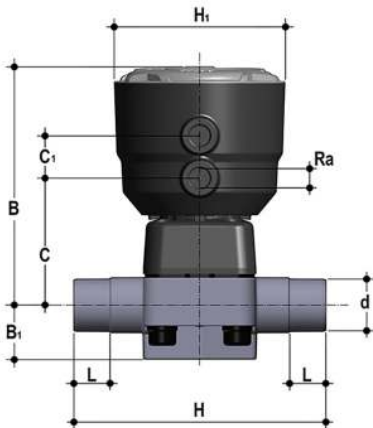

### DKBDC/CP NC

Pneumatically actuated diaphragm valve with male ends for solvent welding, metric series.  
Normally Closed function

d	DN	PN	B	B <sub>1</sub>	C	C <sub>1</sub>	H	H <sub>1</sub>	L	R <sub>0</sub>	g	EPDM Code
20	15	6	134	25	66	24	124	97	16	1/4"	651	DKBDCNC020E
25	20	6	137	30	69	24	144	97	19	1/4"	676	DKBDCNC025E
32	25	6	145	33	78	24	154	97	22	1/4"	881	DKBDCNC032E
40	32	6	149	30	82	24	174	97	26	1/4"	928	DKBDCNC040E
50	40	6	193	35	112	24	194	126	31	1/4"	2536	DKBDCNC050E
63	50	6	231	46	142	24	224	157	38	1/4"	5654	DKBDCNC063E
75	65	6	231	46	142	24	284	157	44	1/4"	5835	DKBDCNC075E

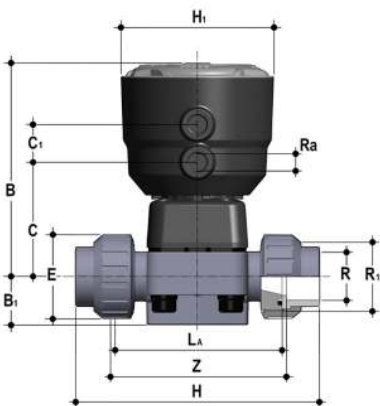

### DKBUIC/CP NC

Pneumatically actuated diaphragm valve with female union ends for solvent welding, metric series Normally Closed function

d	DN	PN	B	B <sub>1</sub>	C	C <sub>1</sub>	E	H	H <sub>1</sub>	L <sub>0</sub>	R <sub>1</sub>	R <sub>0</sub>	Z	g	EPDM Code
20	15	6	134	25	66	24	41	129	97	90	1"	1/4"	100	694	DKBUICNC020E
25	20	6	137	30	69	24	50	154	97	108	1"1/4	1/4"	116	761	DKBUICNC025E
32	25	6	145	33	78	24	58	168	97	116	1"1/2	1/4"	124	997	DKBUICNC032E
40	32	6	149	30	82	24	72	192	97	134	2"	1/4"	140	1130	DKBUICNC040E
50	40	6	193	35	112	24	79	222	126	154	2"1/4	1/4"	160	2768	DKBUICNC050E
63	50	6	231	46	142	24	98	266	157	184	2"3/4	1/4"	190	6068	DKBUICNC063E

# DIMENSIONS

## DKB/CP DN 15÷65 PVC-C

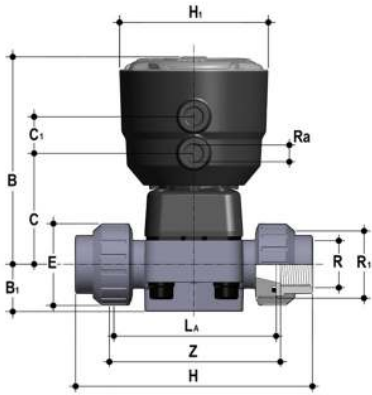

### DKBUFC/CP NC

Pneumatically actuated diaphragm valve with BSP threaded female union ends. Normally Closed function

R	DN	PN	B	B <sub>1</sub>	C	C <sub>1</sub>	E	H	H <sub>1</sub>	L <sub>1</sub>	R <sub>1</sub>	R <sub>2</sub>	Z	g	EPDM Code
1/2"	15	6	134	25	66	24	41	131	97	90	1"	1/4"	97	694	DKBUFCNC012E
3/4"	20	6	137	30	69	24	50	151	97	108	1"1/4	1/4"	118	761	DKBUFCNC034E
1"	25	6	145	33	78	24	58	165	97	116	1"1/2	1/4"	127	997	DKBUFCNC100E
1"1/4	32	6	149	30	82	24	72	188	97	134	2"	1/4"	145	1130	DKBUFCNC114E
1"1/2	40	6	193	35	112	24	79	208	126	154	2"1/2	1/4"	165	2768	DKBUFCNC112E
2"	50	6	231	46	142	24	98	246	157	184	2"3/4	1/4"	195	6068	DKBUFCNC200E

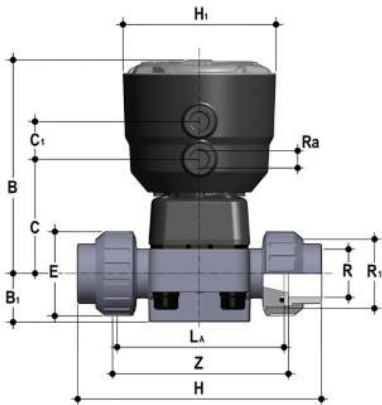

### DKBUAC/CP NC

Pneumatically actuated diaphragm valve with female union ends for solvent welding, ASTM series Normally Closed function

R	DN	PN	B	B <sub>1</sub>	C	C <sub>1</sub>	E	H	H <sub>1</sub>	L <sub>1</sub>	R <sub>1</sub>	R <sub>2</sub>	Z	g	EPDM Code
1/2"	15	6	134	25	66	24	41	143	97	90	1"	1/4"	98	694	DKBUACNC012E
3/4"	20	6	137	30	69	24	50	167	97	108	1"1/4	1/4"	115	761	DKBUACNC034E
1"	25	6	145	33	78	24	58	180	97	116	1"1/2	1/4"	122	997	DKBUACNC100E
1"1/4	32	6	149	30	82	24	72	208	97	134	2"	1/4"	144	1130	DKBUACNC114E
1"1/2	40	6	193	35	112	24	79	234	126	154	2"1/2	1/4"	164	2768	DKBUACNC112E
2"	50	6	231	46	142	24	98	272	157	184	2"3/4	1/4"	195	6068	DKBUACNC200E

# DIMENSIONS

## DKB/CP DN 15÷65 PVC-C

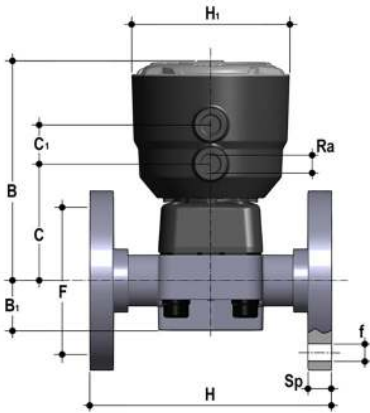

### DKBOC/CP NC

Pneumatically actuated diaphragm valve with monolithic flanged body, drilled PN10/16. Face to face according to EN 558-1. Normally Closed function

d	DN	PN	B	B <sub>1</sub>	C	C <sub>1</sub>	F	f	H	H <sub>1</sub>	R <sub>3</sub>	U	Sp	g	EPDM Code
20	15	6	134	25	66	24	65	14	130	97	1/4"	4	13.5	912	DKBOCNC020E
25	20	6	137	30	69	24	75	14	150	97	1/4"	4	13.5	1003	DKBOCNC025E
32	25	6	145	33	78	24	85	14	160	97	1/4"	4	13.5	1289	DKBOCNC032E
40	32	6	149	30	82	24	100	18	180	97	1/4"	4	14	1503	DKBOCNC040E
50	40	6	193	35	112	24	110	18	200	126	1/4"	4	16	3271	DKBOCNC050E
63	50	6	231	46	142	24	125	18	230	157	1/4"	4	16	6542	DKBOCNC063E
75	65	6	231	46	142	24	145	18	290	157	1/4"	4	21	7485	DKBOCNC075E

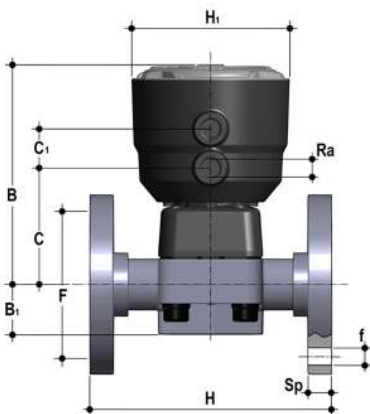

### DKBOAC/CP NC

Pneumatically actuated diaphragm valve with monolithic flanged body, drilled ANSI B16.5 cl. 150 #FF. Normally Closed function

d	DN	PN	B	B <sub>1</sub>	C	C <sub>1</sub>	F	f	H	H <sub>1</sub>	R <sub>3</sub>	U	Sp	g	EPDM Code
1/2"	15	6	134	25	66	24	60.30	14	108	97	1/4"	4	13.5	912	DKBOACNC012E
3/4"	20	6	137	30	69	24	69.90	15.7	120	97	1/4"	4	13.5	1003	DKBOACNC034E
1"	25	6	145	33	78	24	79.40	15.7	131	97	1/4"	4	13.5	1289	DKBOACNC100E
1" 1/4	32	6	149	30	82	24	88.90	15.7	162	97	1/4"	4	14	1503	DKBOACNC114E
1" 1/2	40	6	193	35	112	24	98.40	15.7	180	126	1/4"	4	16	3271	DKBOACNC112E
2"	50	6	231	46	142	24	120.70	19	210	157	1/4"	4	16	6542	DKBOACNC200E
2" 1/2	65	6	231	46	142	24	139.70	19	250	157	1/4"	4	21	7485	DKBOACNC212E

# DIMENSIONS

## DKB/CP DN 15÷65 PP-H

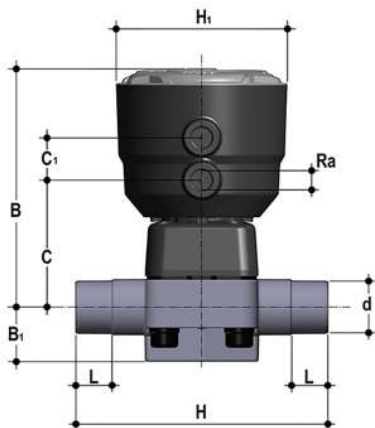

### DKBDM/CP NC

Pneumatically actuated diaphragm valve with male ends for socket welding, metric series  
Normally Closed function

d	DN	PN	B	B <sub>1</sub>	C	C <sub>1</sub>	H	H <sub>1</sub>	L	R <sub>0</sub>	g	EPDM Code
20	15	6	134	25	66	24	124	97	16	1/4"	615	DKBDMNC020E
25	20	6	137	30	69	24	144	97	19	1/4"	630	DKBDMNC025E
32	25	6	145	33	78	24	154	97	22	1/4"	805	DKBDMNC032E
40	32	6	149	30	82	24	174	97	26	1/4"	835	DKBDMNC040E
50	40	6	193	35	112	24	194	126	31	1/4"	2342	DKBDMNC050E
63	50	6	231	46	142	24	224	157	38	1/4"	5480	DKBDMNC063E
75	65	6	231	46	142	24	284	157	44	1/4"	5630	DKBDMNC075E

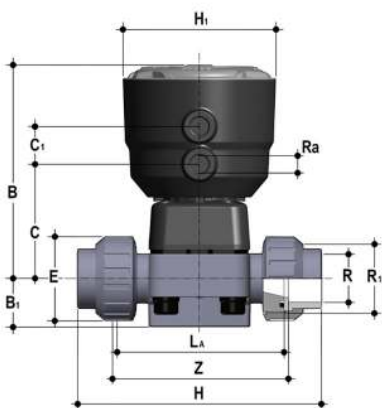

### DKBUIM/CP NC

Pneumatically actuated diaphragm valve with female union ends for socket welding, metric series  
Normally Closed function

d	DN	PN	B	B <sub>1</sub>	C	C <sub>1</sub>	E	H	H <sub>1</sub>	L <sub>0</sub>	R <sub>1</sub>	R <sub>0</sub>	Z	g	EPDM Code
20	15	6	134	25	66	24	41	129	97	90	1"	1/4"	100	639	DKBUIMNC020E
25	20	6	137	30	69	24	50	154	97	108	1"1/4	1/4"	116	685	DKBUIMNC025E
32	25	6	145	33	78	24	58	168	97	116	1"1/2	1/4"	124	880	DKBUIMNC032E
40	32	6	149	30	82	24	72	192	97	134	2"	1/4"	140	966	DKBUIMNC040E
50	40	6	193	35	112	24	79	222	126	154	2"1/4	1/4"	160	2511	DKBUIMNC050E
63	50	6	231	46	142	24	98	266	157	184	2"3/4	1/4"	190	5609	DKBUIMNC063E



# DIMENSIONS

## DKB/CP DN 15÷65 PP-H

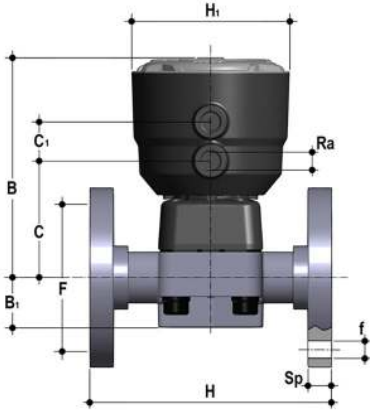

### DKBOM/CP NC

Pneumatically actuated diaphragm valve with monolithic flanged body, drilled PN10/16. Face to face according to EN 558-1. Normally Closed function

d	DN	PN	B	B <sub>1</sub>	C	C <sub>1</sub>	F	f	H	H <sub>t</sub>	R <sub>3</sub>	U	Sp	g	EPDM Code
20	15	6	134	25	66	24	65	14	130	97	1/4"	4	13.5	767	DKBOMNC020E
25	20	6	137	30	69	24	75	14	150	97	1/4"	4	13.5	815	DKBOMNC025E
32	25	6	145	33	78	24	85	14	160	97	1/4"	4	13.5	1059	DKBOMNC032E
40	32	6	149	30	82	24	100	18	180	97	1/4"	4	14	1144	DKBOMNC040E
50	40	6	193	35	112	24	110	18	200	126	1/4"	4	16	2743	DKBOMNC050E
63	50	6	231	46	142	24	125	18	230	157	1/4"	4	16	5795	DKBOMNC063E
75	65	6	231	46	142	24	145	18	290	157	1/4"	4	21	6339	DKBOMNC075E

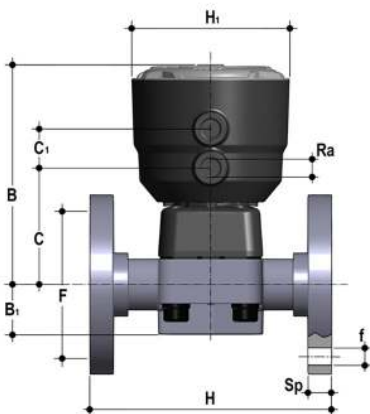

### DKBOAM/CP NC

Pneumatically actuated diaphragm valve with monolithic flanged body, drilled ANSI B16.5 cl. 150 #FF. Normally Closed function

d	DN	PN	B	B <sub>1</sub>	C	C <sub>1</sub>	F	f	H	H <sub>t</sub>	R <sub>3</sub>	U	Sp	g	EPDM Code
1/2"	15	6	134	25	66	24	60.30	14	108	97	1/4"	4	13.5	767	DKBOAMNC012E
3/4"	20	6	137	30	69	24	69.90	15.7	120	97	1/4"	4	13.5	815	DKBOAMNC034E
1"	25	6	145	33	78	24	79.40	15.7	131	97	1/4"	4	13.5	1059	DKBOAMNC100E
1" 1/4	32	6	149	30	82	24	88.90	15.7	162	97	1/4"	4	14	1144	DKBOAMNC114E
1" 1/2	40	6	193	35	112	24	98.40	15.7	180	126	1/4"	4	16	2743	DKBOAMNC112E
2"	50	6	231	46	142	24	120.70	19	210	157	1/4"	4	16	5795	DKBOAMNC200E
2" 1/2	65	6	231	46	142	24	139.70	19	250	157	1/4"	4	21	6339	DKBOAMNC212E

# FASTENING AND SUPPORTING



All valves, whether manual or actuated, must be adequately supported in many applications.

The DKB valve series is therefore provided with an integrated bracket that permits direct anchoring on the valve body without the need of other components.

For wall or panel installation, dedicated PMDK mounting plates which are available as accessories can be used. These plates should be fastened to the valve before wall installation.

PMDK plates also allow DKB valve alignment with FIP ZIKM pipe clips.

d	DN	h	l	J
20	15	10	25	M6
25	20	10	25	M6
32	25	10	25	M6
40	32	10	25	M6
50	40	13	44.5	M8
63	50	13	44.5	M8
75	65	13	44.5	M8

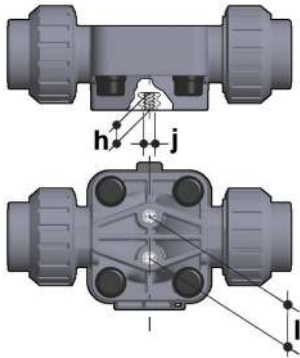

# COMPONENTS

## EXPLODED VIEW DN 15÷65

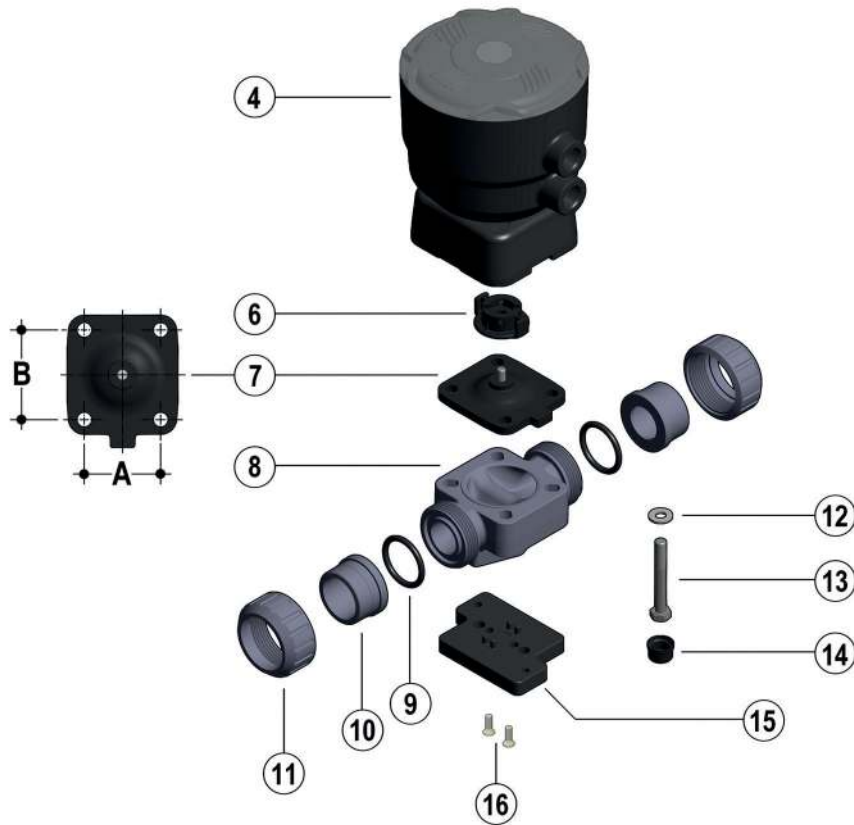

DN	15	20	25	32	40	50	65
A	40	40	46	46	65	78	78
B	44	44	54	54	70	82	82

- 4** Actuator (PP-GR - 1)\*
- 6** Compressor (PA-GR IXEF® - 1)
- 7** Seal diaphragm (EPDM - 1)\*
- 8** Valve body (PVC-U, PVCC, PP-H - 1)\*
- 9** Socket seal O-Ring (EPDM - 2)\*
- 10** End connector (PVC-U, PVCC, PP-H - 2)\*
- 11** Union nut (PVC-U, PVCC, PP-H - 2)\*
- 12** Washer (Acciaio INOX - 4)
- 13** Bolt (Acciaio INOX - 4)
- 14** Protection plug (PE - 4)
- 15** Distance plate (PP-GR - 1)\*\*
- 16** Screw (STAINLESS steel - 2)\*\*

\* Spare parts

\*\* Accessories

The material the component is made of and the quantity supplied are shown in brackets

## DISASSEMBLY

- 1) Isolate the valve from the line (release the pressure and empty the pipeline).
- 2) Open the valve with compressed air to drain any residual liquid from the valve.
- 3) Disconnect the valve from the pneumatic and electrical connections.
- 4) Unscrew the union nuts (11) and extract the valve.
- 5) Remove the protection plugs (14) and remove the bolts (13) with the relative washers (12).
- 6) Separate the valve body (8) from the actuator (4).
- 7) Unscrew the diaphragm (7) and remove the compressor (6).

## ASSEMBLY

- 1) Insert the compressor (6) on the actuator stem (4), aligning it correctly in its housing (fig. 3).
- 2) Screw the diaphragm (7) onto the stem, aligning it correctly with its housing on the actuator.
- 3) Mount the actuator (4) on the valve body (8) and screw in the bolts (13) with the relative washers (12).
- 4) Tighten the bolts (13) evenly (diagonally) to the tightening torque suggested on the relative instruction sheet.
- 5) Replace the protection plugs (14).
- 6) Position the valve between the end connectors (10) and tighten the union nuts (11), making sure that the socket seal O-rings (9) do not exit their seats.
- 7) Reconnect the valve to the pneumatic and electrical connections.



**Note:** All operations on equipment under pressure or containing compressed springs must be carried out under safe conditions for the operator.

Fig. 3



Fig. 4



## INSTALLATION

Before proceeding with installation, please follow these instructions carefully: (instructions refer to versions with union ends). The valve can be installed in any position and in any direction.

- 1) Check that the pipes to be connected to the valve are aligned in order to avoid mechanical stress on the threaded joints.
- 2) Unscrew the union nuts (11) and insert them on the pipe segments.
- 3) Solvent weld or screw the end connectors (10) onto the pipe ends.
- 4) Position the valve body between the end connectors making sure the socket seal O-Rings (9) do not exit the seats.
- 5) Completely tighten the union nuts (11).
- 6) If necessary, support the pipework with FIP pipe clips or by means of the carrier built into the valve itself (see paragraph "Fastening and supporting").
- 7) Connect the compressed air as indicated in paragraph "Compressed air connections". For valves with electric accessories, refer to the specific technical manual supplied with the accessory.

When installing in confined spaces, the connections can be oriented in line with the piping. (Fig. 4).

## WARNINGS

**Note:** before putting the valve into service, check that the bolts on the valve body (8) are tightened correctly at the suggested torque.